

1	2	3	4	5	6	7	8
---	---	---	---	---	---	---	---

THIS DRAWING AND SPECIFICATIONS, HEREIN, ARE THE PROPERTY OF INVENTEC CORPORATION AND SHALL NOT BE REPRODUCED, COPIED, OR USED IN WHOLE OR IN PART AS THE BASIS FOR THE MANUFACTURE OR SALE OF ITEMS WITHOUT WRITTEN PERMISSION. INVENTEC CORPORATION 2009 ALL RIGHT RESERVED

A

A

B

B

C

C

D

D

E

E

F

F

GUCCI 1.0

PV BUILD

2009.04.22

DATE	CHANGE NO.	REV

DRAWER	EE	DATE	POWER	DATE	INVENTEC			
DESIGN								
CHECK								
RESPONSIBLE								
TITLE					GUCCI10			
SIZE =	3	VER :						
FILE NAME :	XXXX-XXXXXX-XX				SIZE	CODE	DOC. NUMBER	REV
P/N	XXXXXXXXXXXX				A3	CS	1310A2255301-0-MTR	A01
					SHEET	1	OF	50

1	2	3	4	5	6	7	8
---	---	---	---	---	---	---	---

TABLE OF CONTENTS

PAGE	PAGE	PAGE
1. COVER PAGE	13. CLOCK_GENERATOR	36. WLAN / WWAN / SIM
2. INDEX	14. ATOM-1	37. LAN CONTROLLER
3. BLOCK DIAGRAM	15. ATOM-2	38. LAN RJ45
4. POWER SEQUENCE BLOCK	16. ATOM-3	39. CARD READER
5. CHARGER & OCP	17. ATOM-4	40. ACCELEROMETER & HDD CONN & USB CONN
6. SELECT & BATTERY CONN	18. FAN & THERMAL CONTROLLER	41. SPI & KEYBOARD CONN & TOUCHPAD CONN
7. SYSTEM POWER (3V/5V)	19. 945GSE-1	42. KBC1070
8. SYSTEM POWER (+V1.8 / +VCCP)	20. 945GSE-2	43. LID & LED
9. CPU CORE POWER	21. 945GSE-3	44. BLUETOOTH & WIRELESS SWITCH
10. SYSTEM POWER(2.5S / 1.5S / 0.9S)	22. 945GSE-4	45. EMI CAP
11. POWER SLEEP	23. 945GSE-5	46. CODEC(1984A)
12. POWER(SEQUENCE)	24. 945GSE-6	47. SPEAKER & MIC
	25. 945GSE-7~8	48. HEADPHONE & INT MIC
	26. DDR2 DIMM0	49. POWER SWITCH DB
	27. DDR2 PULL UP TERMINATOR	50. DAUGHTER BOARD TOUCHPAD
	28. CRT	
	29. LCM & WEBCAM CONN	
	30. ICH7-1	
	31. ICH7-2	
	32. ICH7-3	
	33. ICH7-4	
	34. ICH7-5	
	35. ICH7-6	

INVENTEC

TITLE
GUCCI10

SIZE A3	CODE CS	DOC. NUMBER <i>1310a2255301-0-MTR</i>	REV A01
-------------------	-------------------	--	-------------------

CHANGE by *Phil Huang* *11-Apr-2009* SHEET **2** OF **50**

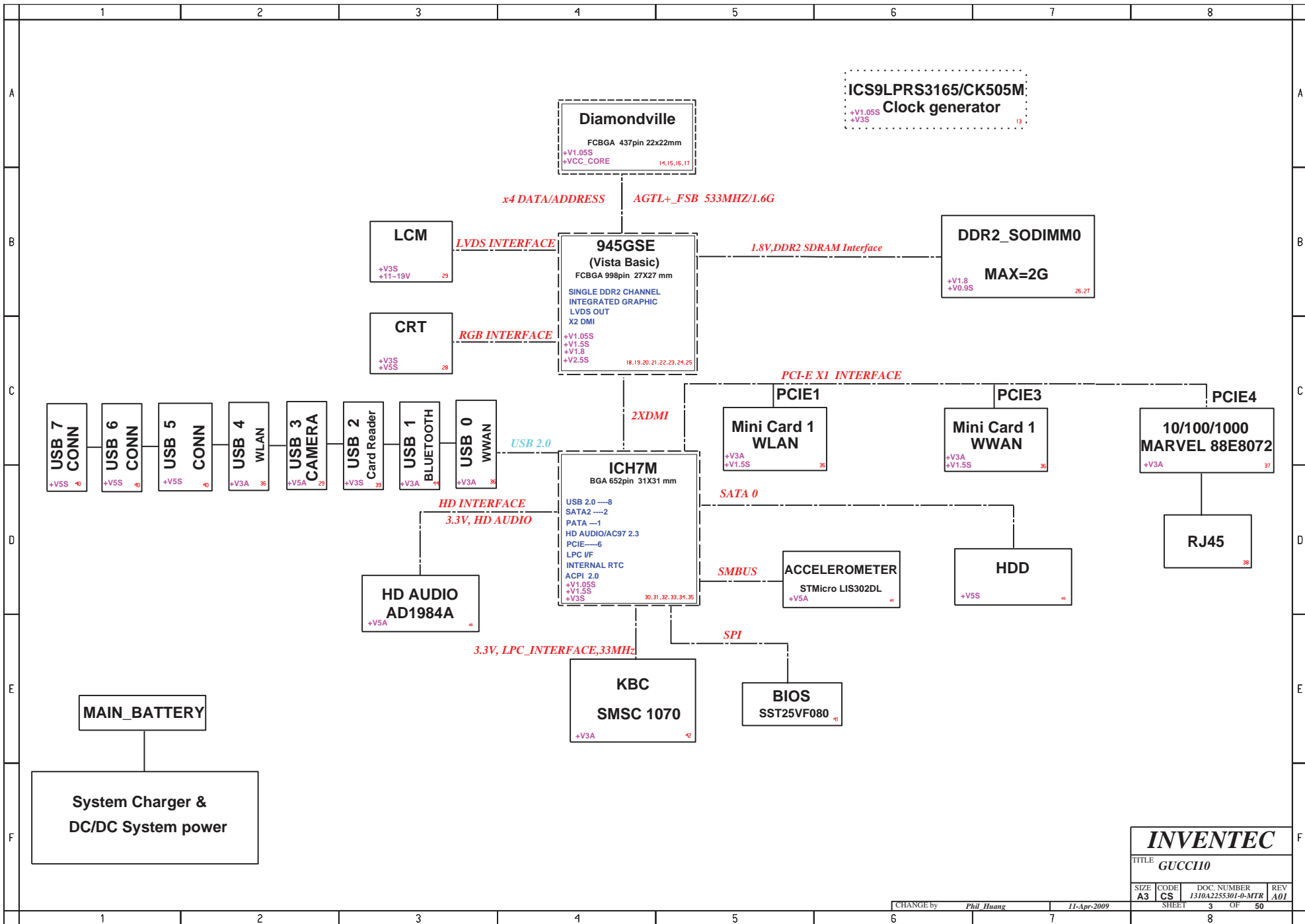

INVENTEC			
TITLE GUCCII0			
SIZE A3	CODE CS	DOC. NUMBER 1310A2255301-0-MTR	REV A01
CHANGE by <i>Phil Huang</i>		11-Apr-2009	
SHEET		OF 50	
1		8	

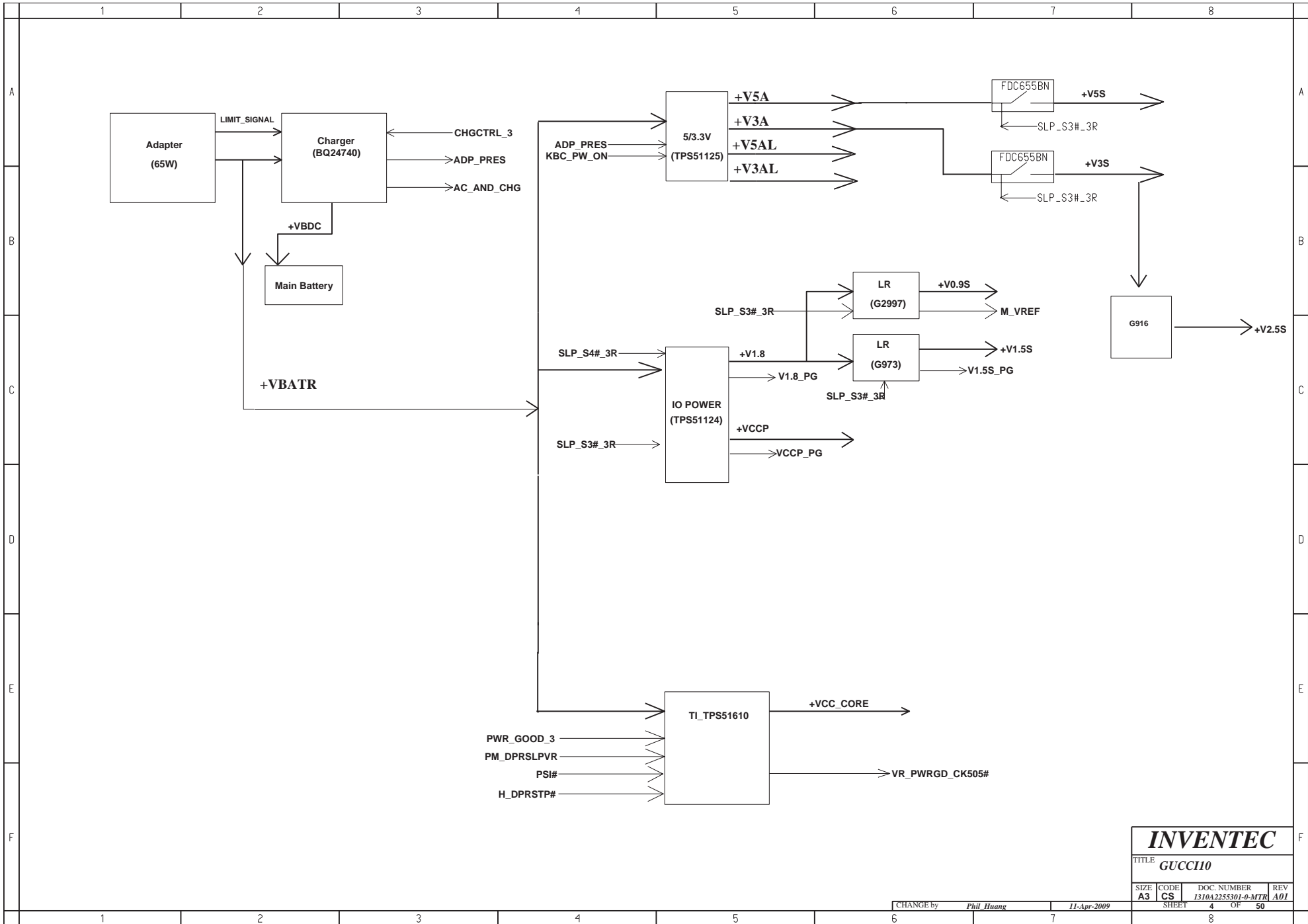

INVENTEC

TITLE **GUCC110**

SIZE	CODE	DOC. NUMBER	REV
A3	CS	1310A2255301-0-MTR	A01

CHANGE by *Phil Huang* 11-Apr-2009

SHEET 4 OF 50

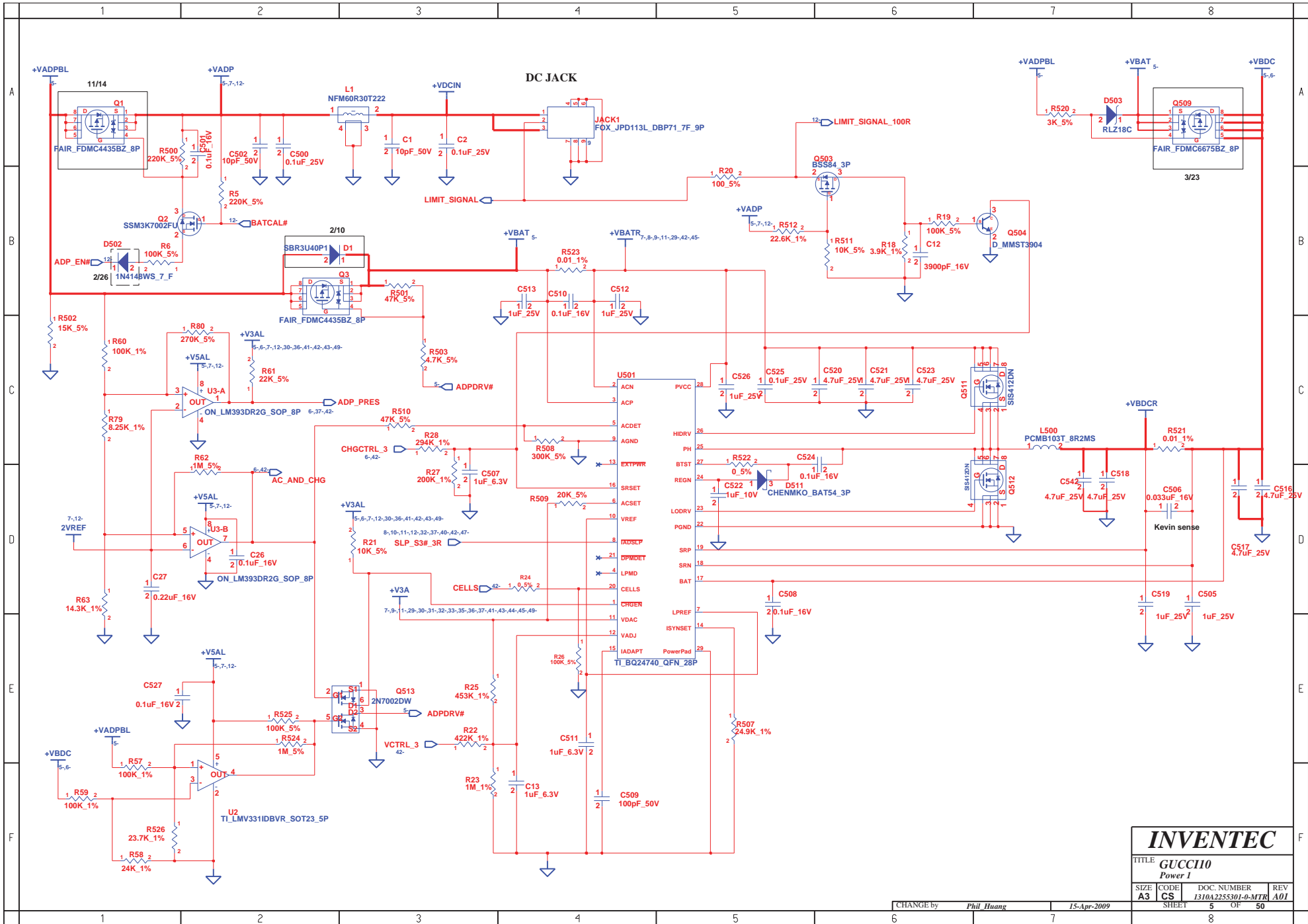

INVENTEC			
TITLE GUCCIO			
Power 1			
SIZE	CODE	DOC. NUMBER	REV
A3	CS	1310A2255301-0-MTR	A01
CHANGE by <i>Phil Huang</i>		15-Apr-2009	
SHEET		5 OF 50	

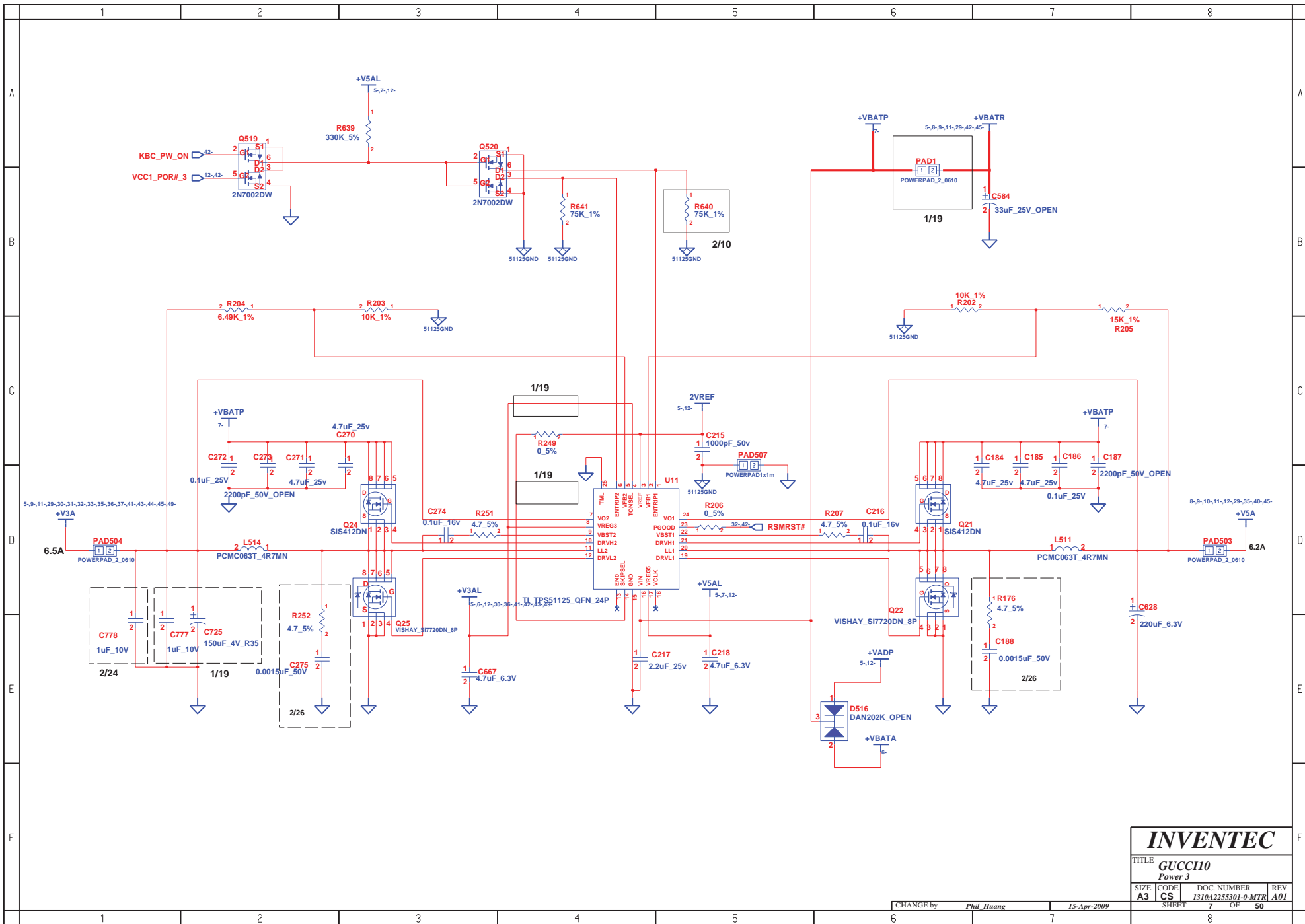

INVENTEC			
TITLE GUCC110			
Power 3			
SIZE A3	CODE CS	DOC. NUMBER 1310A2255301-0-MTR	REV A01
CHANGE by <i>Phil Huang</i>		15-Apr-2009	
SHEET 7		OF 50	

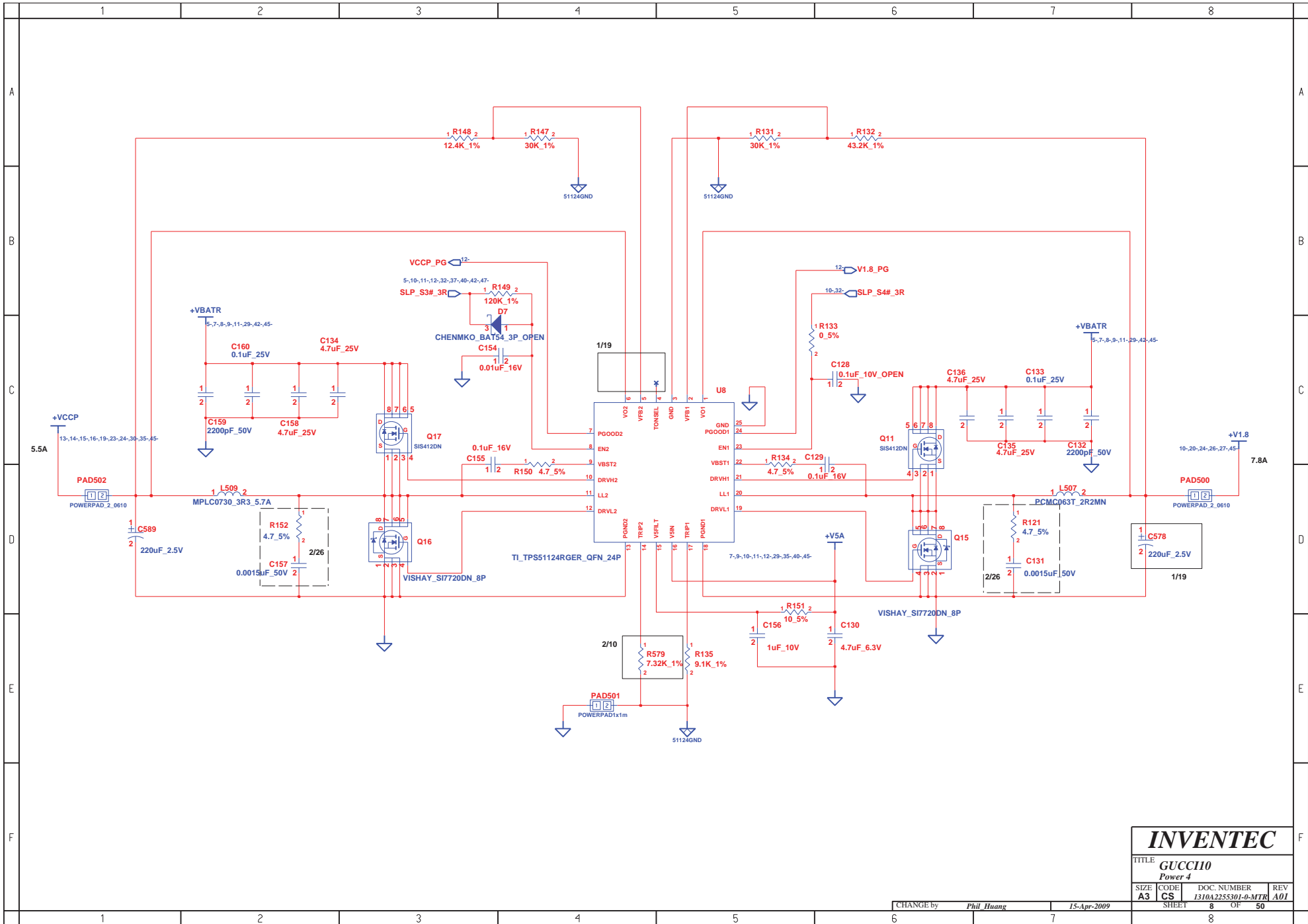

INVENTEC

TITLE
GUCC110
 Power 4

SIZE CODE DOC. NUMBER REV
A3 CS 1310A2255301-0-MTR A01

CHANGE by Phil Huang 15-Apr-2009 SHEET 8 OF 50

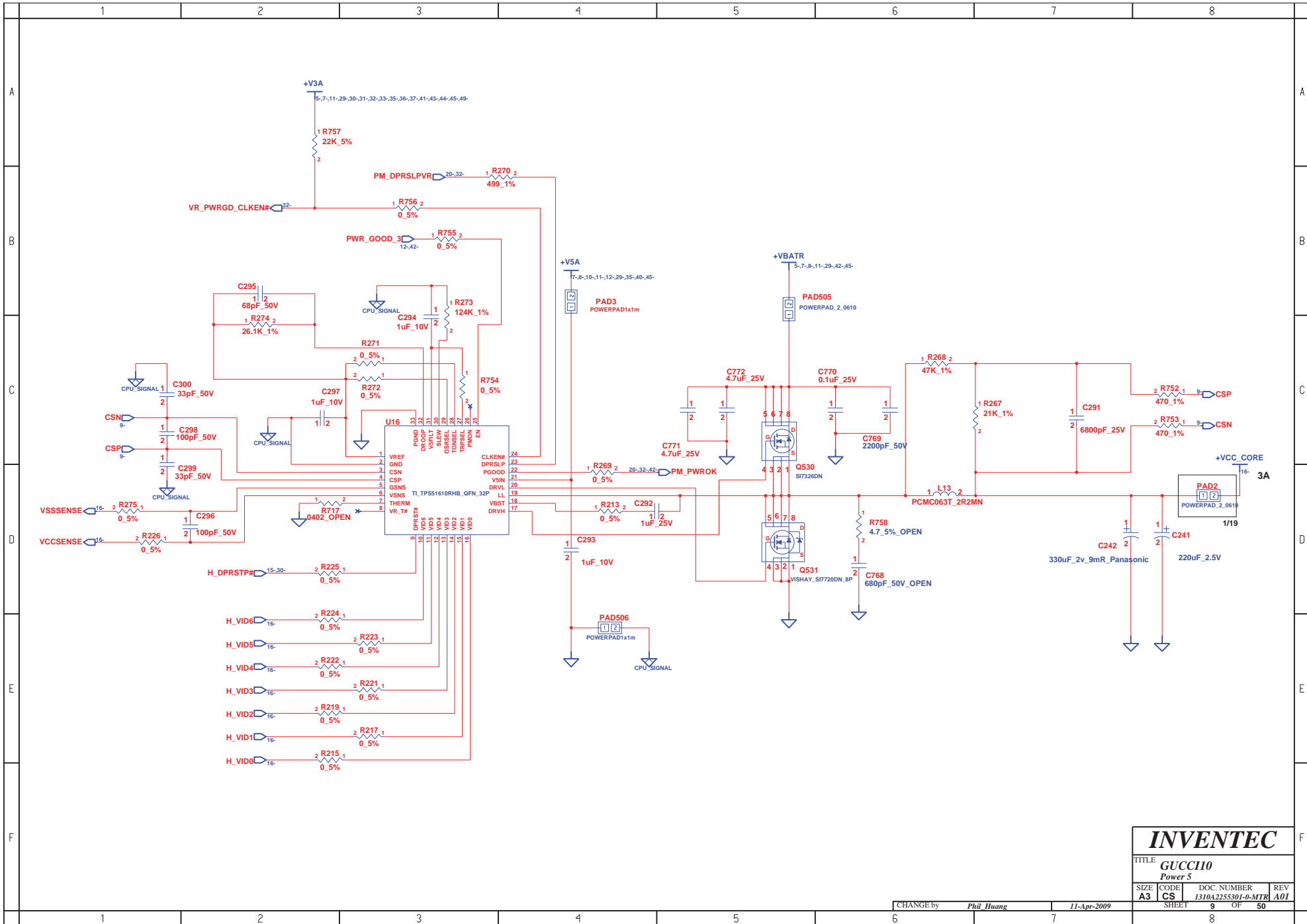

INVENTEC

TITLE			GUCC110		
			Power 5		
SIZE	CODE	DOC. NUMBER	REV		
A3	CS	1310A2255301-0-MTR	A01		
CHANGE by			SHEET		
Phil Huang			9 OF 50		

11-Apr-2009

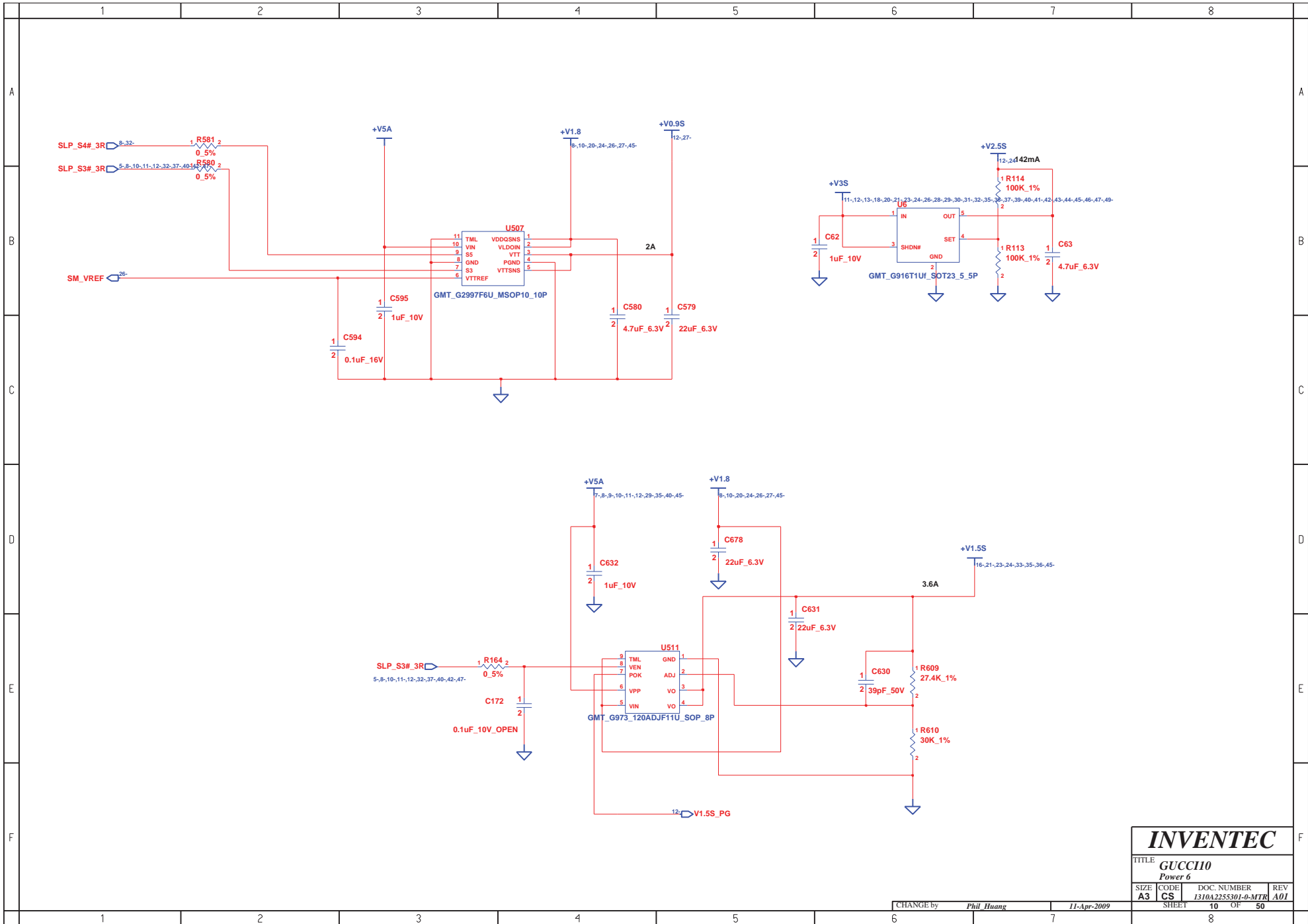

INVENTEC

TITLE
GUCC110
 Power 6

SIZE A3	CODE CS	DOC. NUMBER 1310A2255301-0-MTR	REV A01
CHANGE by Phil Huang		11-Apr-2009	
SHEET 10		OF 50	

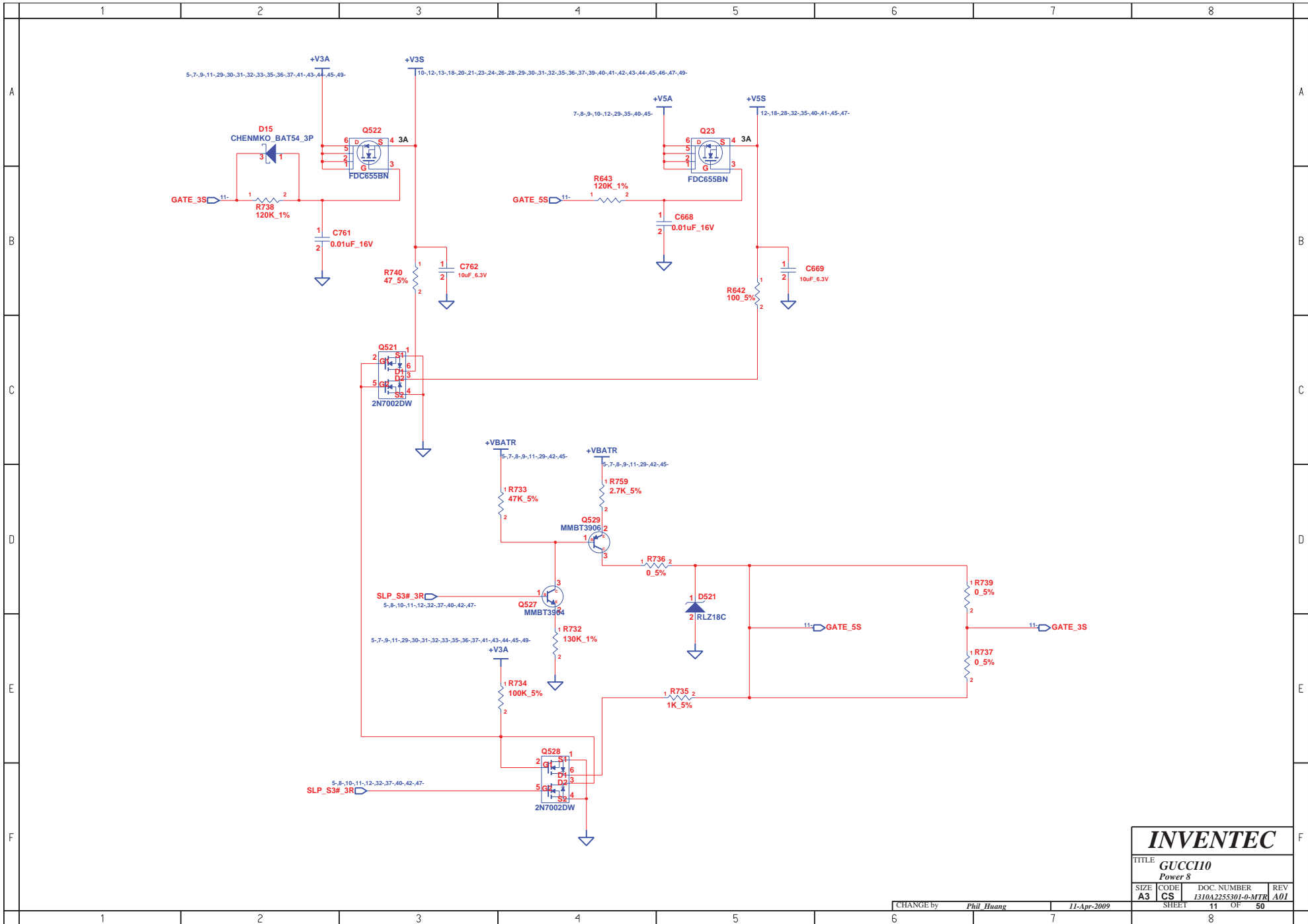

INVENTEC			
TITLE GUCC110			
Power 8			
SIZE A3	CODE CS	DOC. NUMBER 1310A2255301-0-MTR	REV A01
CHANGE by <i>Phil Huang</i>		11-Apr-2009	
SHEET 11		OF 50	

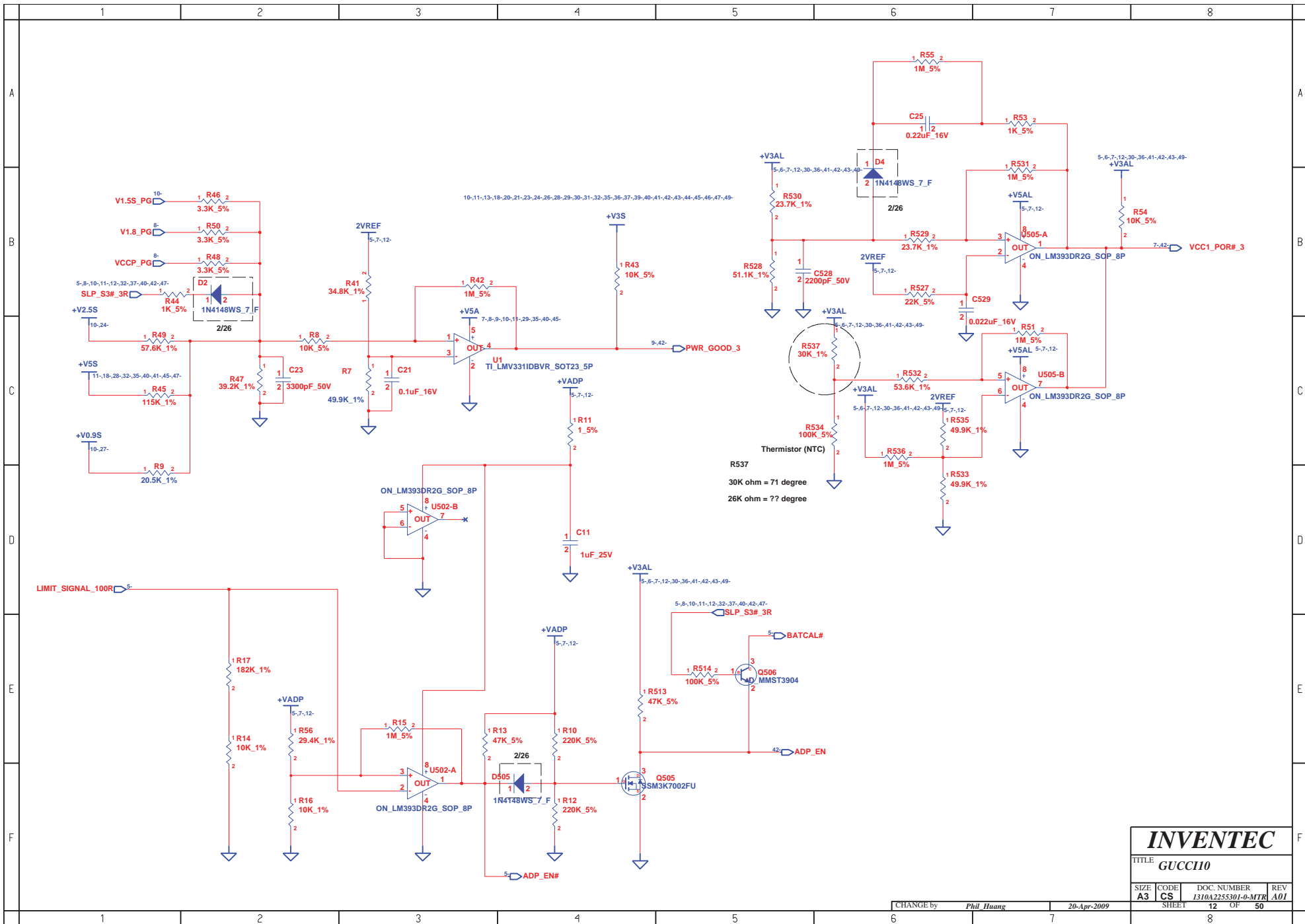

INVENTEC			
TITLE GUCC110			
SIZE A3	CODE CS	DOC. NUMBER 1310A225301-0-MTR	REV A01
CHANGE by Phil Huang		20-Apr-2009	
SHEET 12		OF 50	

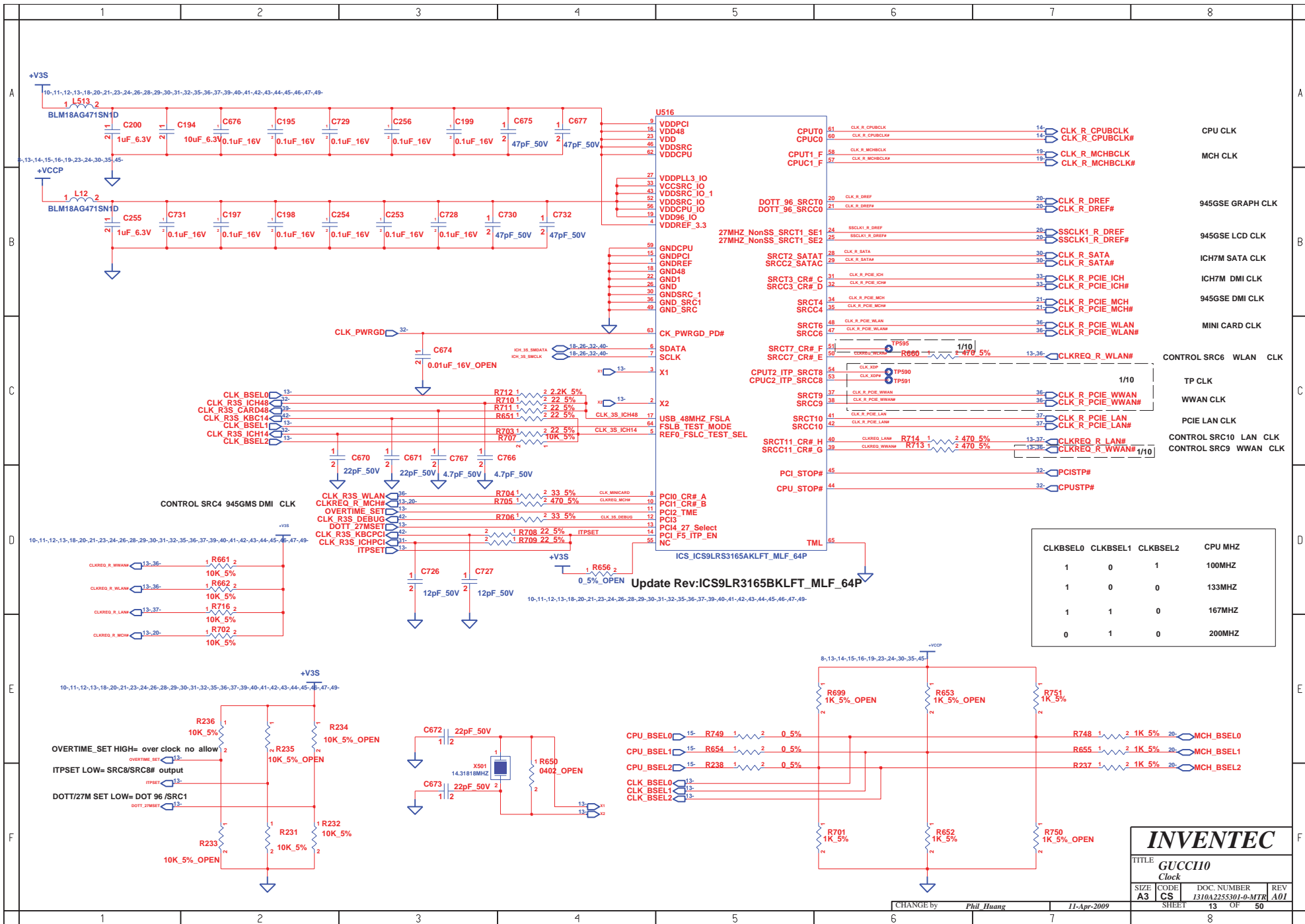

INVENTEC

TITLE: **GUCC110**
Clock

SIZE	CODE	DOC. NUMBER	REV
A3	CS	1310A2255301-0-MTR	A01

CHANGE by: *Phil Huang* 11-Apr-2009

SHEET 13 OF 50

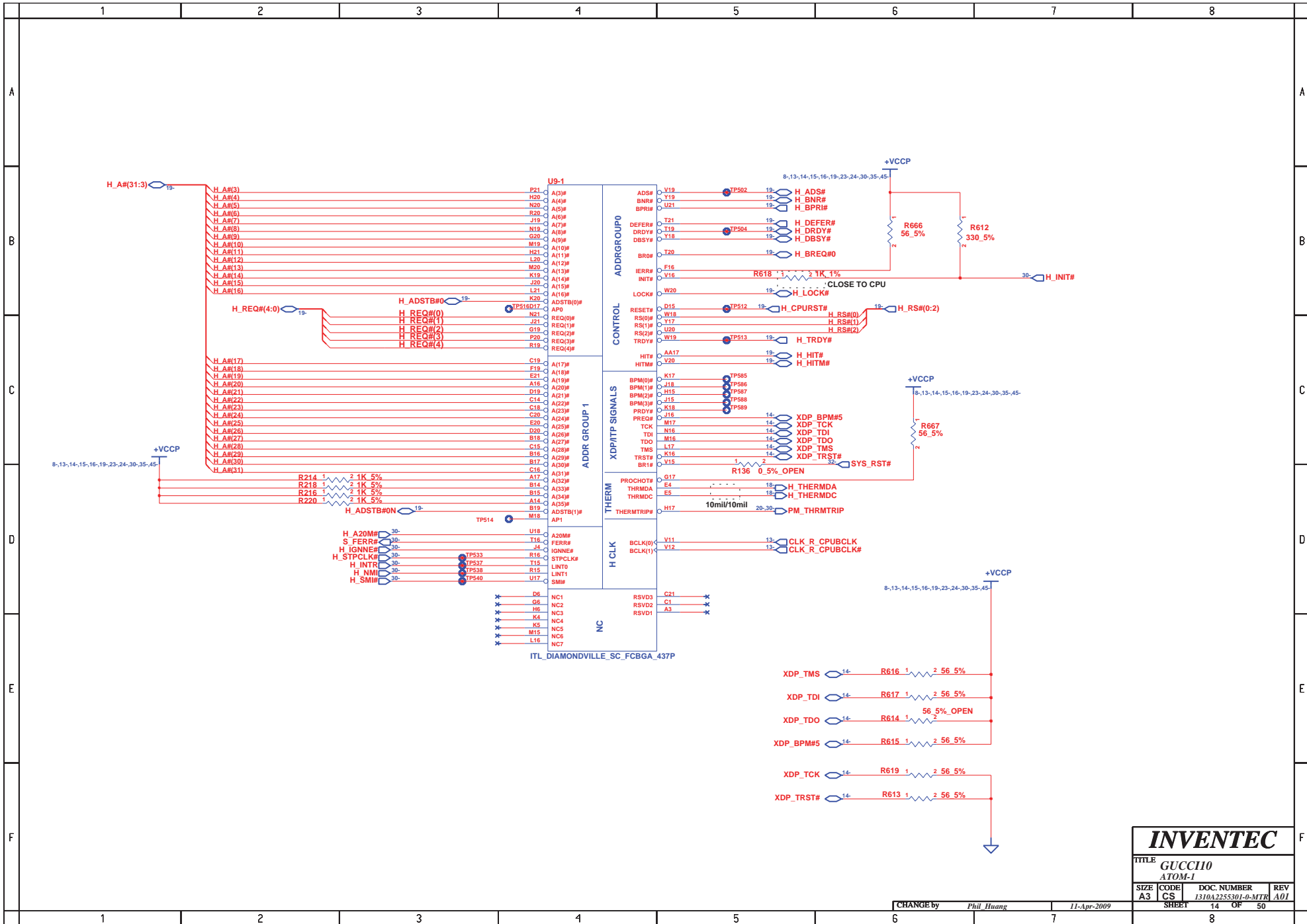

INVENTEC			
TITLE GUCC110 ATOM-1			
SIZE A3	CODE CS	DOC. NUMBER 1310A2255301-0-MTR	REV A01
CHANGE by Phil Huang		11-Apr-2009	
SHEET 14		OF 50	

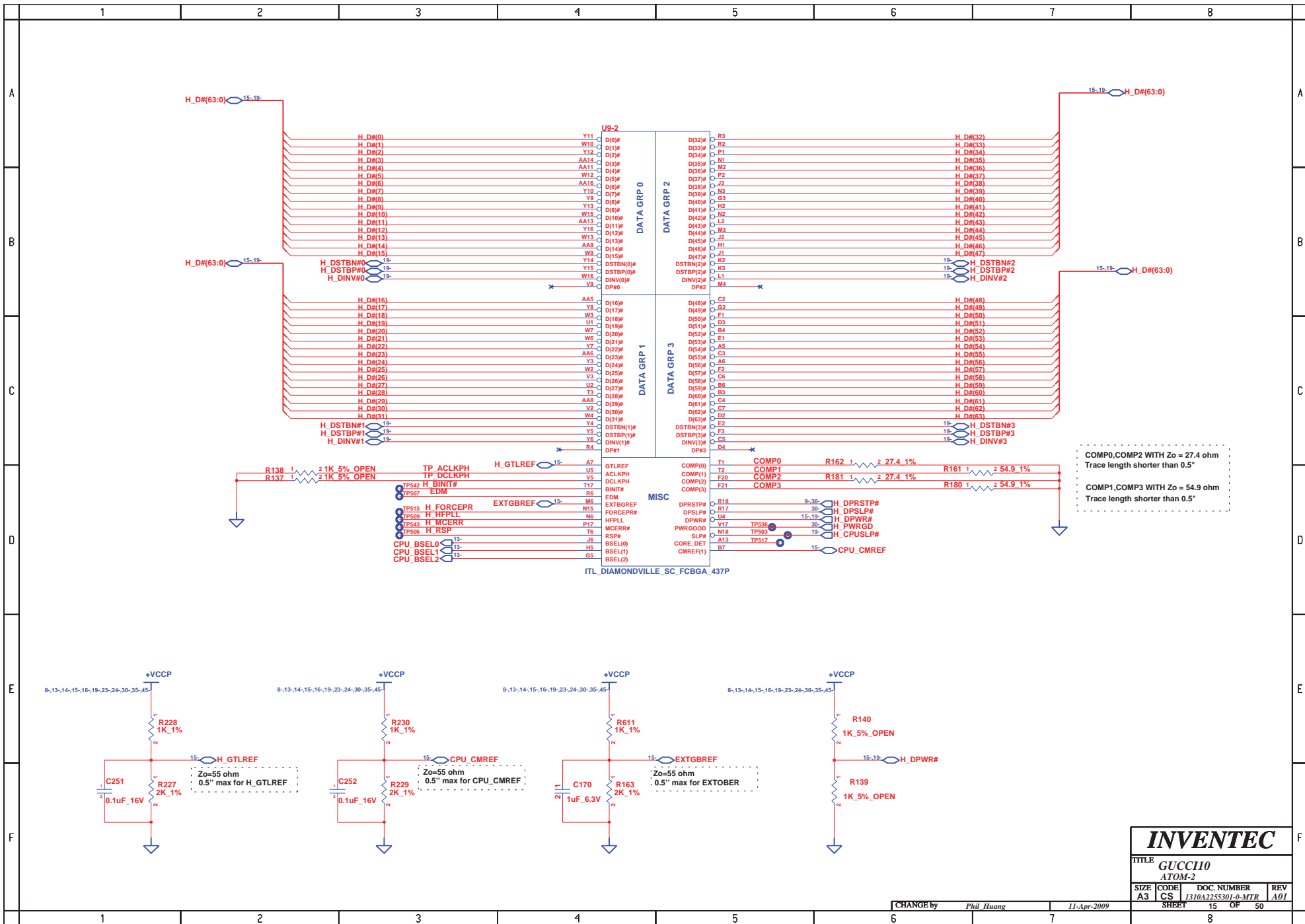

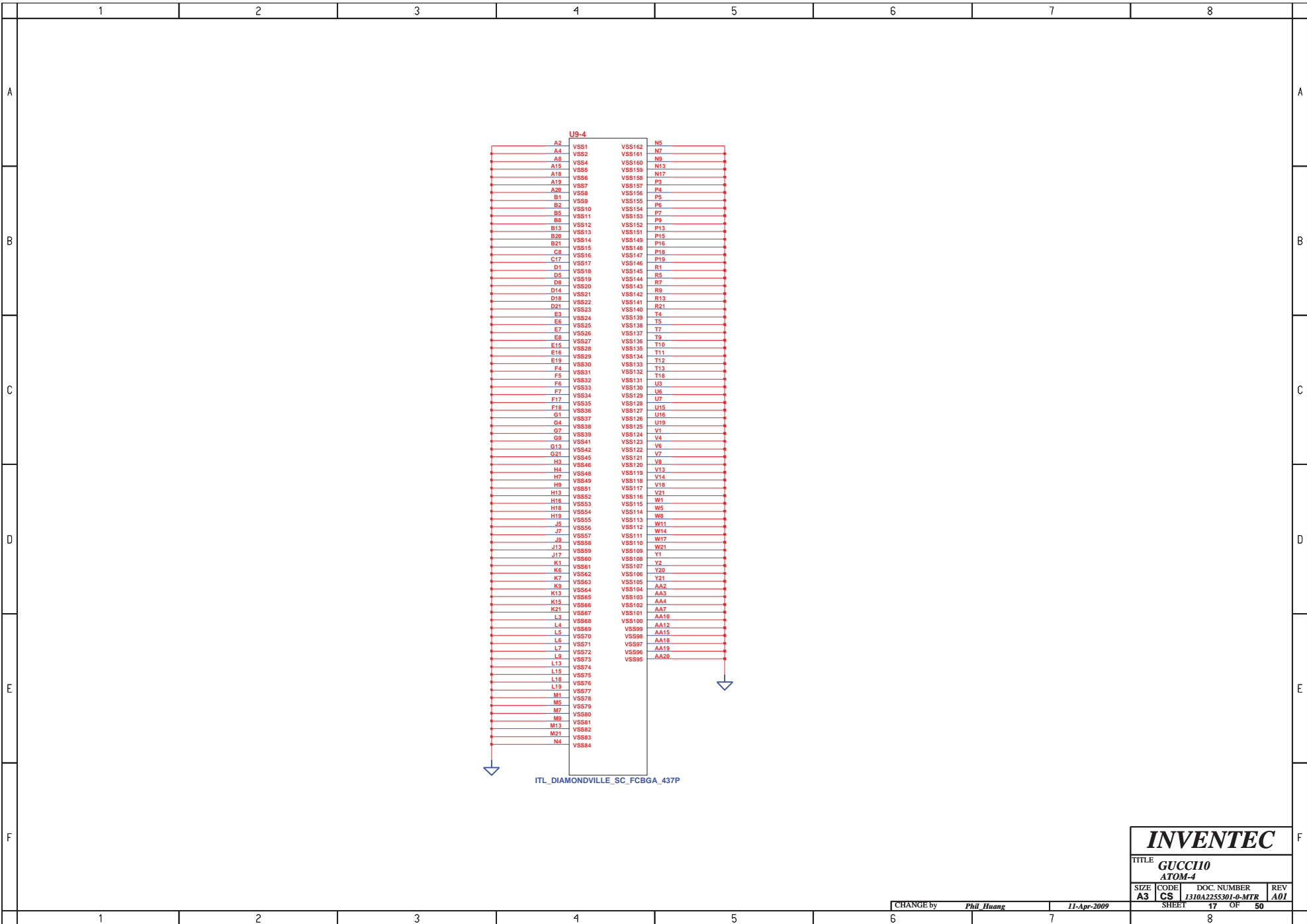

INVENTEC			
TITLE GUCCIO			
ATOM-4			
SIZE A3	CODE CS	DOC. NUMBER 1310A2255301-0-MTR	REV A01
CHANGE by <i>Phil Huang</i>		11-Apr-2009	
SHEET 17		OF 50	

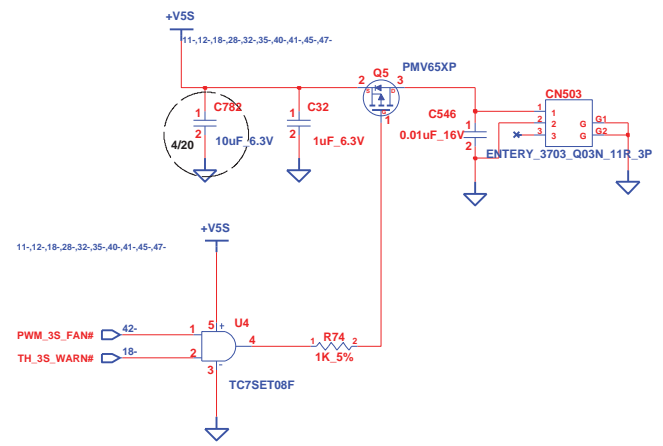
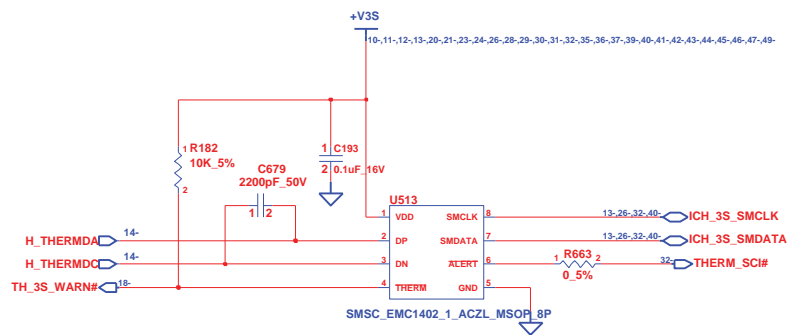

INVENTEC			
TITLE GUCCI10 Fan & Thermal & XDP			
SIZE A3	CODE CS	DOC. NUMBER 1310A2255301-0-MTR	REV A01
CHANGE by <i>Phil Huang</i>		SHEET 18 OF 50	

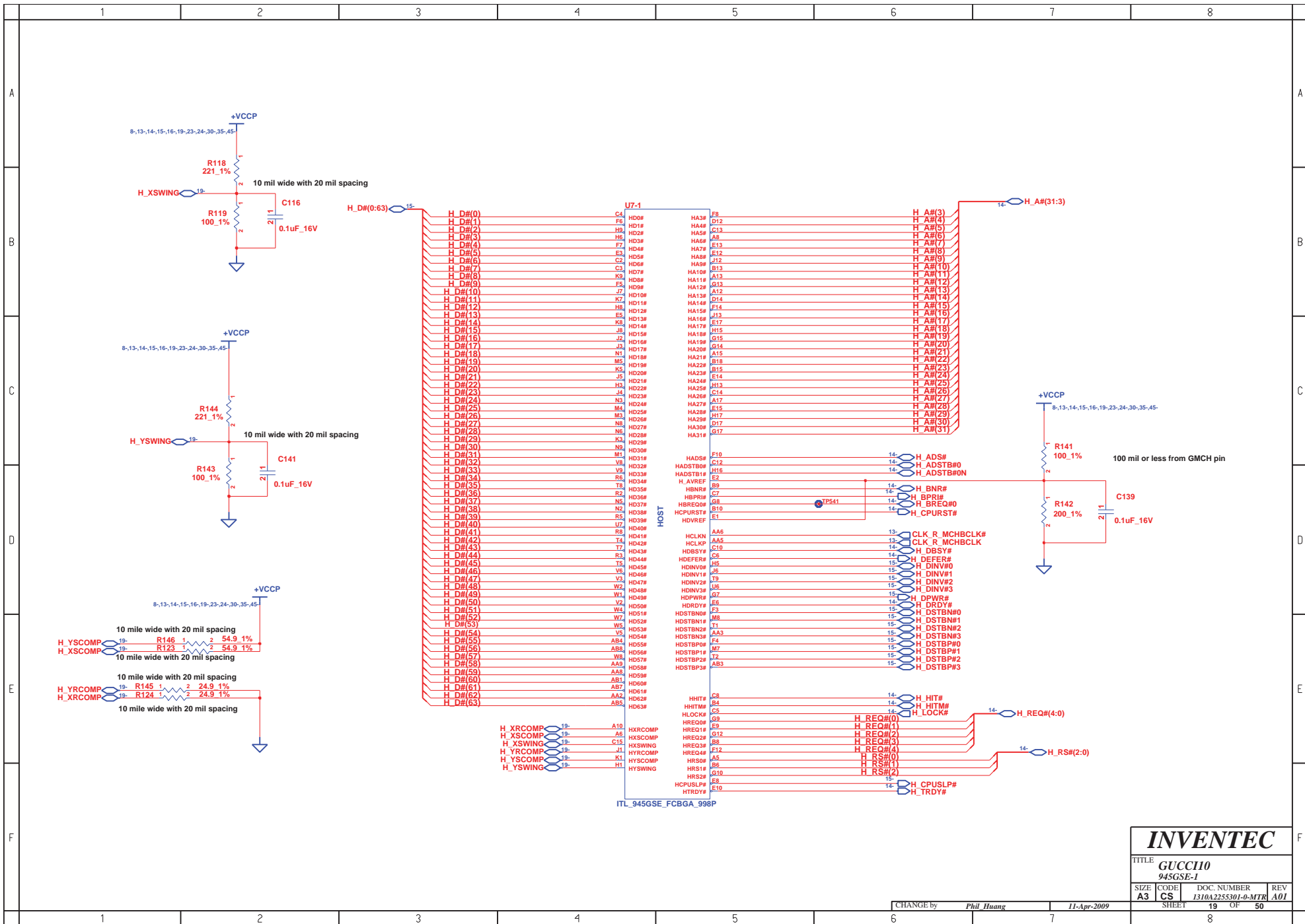

INVENTEC

TITLE: **GUCC110**
945GSE-1

SIZE	CODE	DOC. NUMBER	REV
A3	CS	1310A2255301-0-MTR	A01

CHANGE by: *Phil Huang* 11-Apr-2009

SHEET 19 OF 50

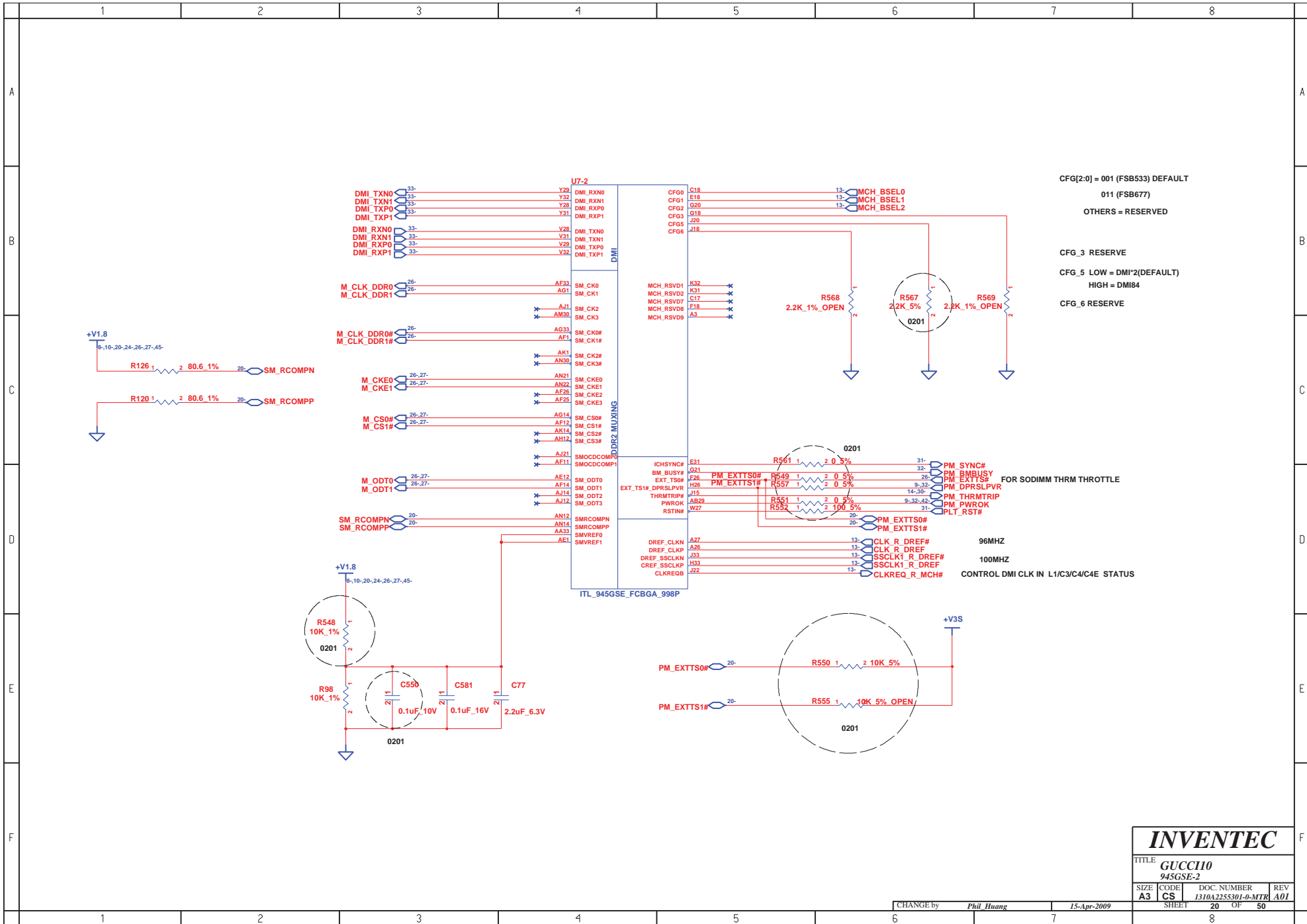

INVENTEC			
TITLE GUCC110 945GSE-2			
SIZE A3	CODE CS	DOC. NUMBER 1310A2255301-0-MTR	REV A01
CHANGE by <i>Phil Huang</i>		15-Apr-2009	
SHEET 20		OF 50	

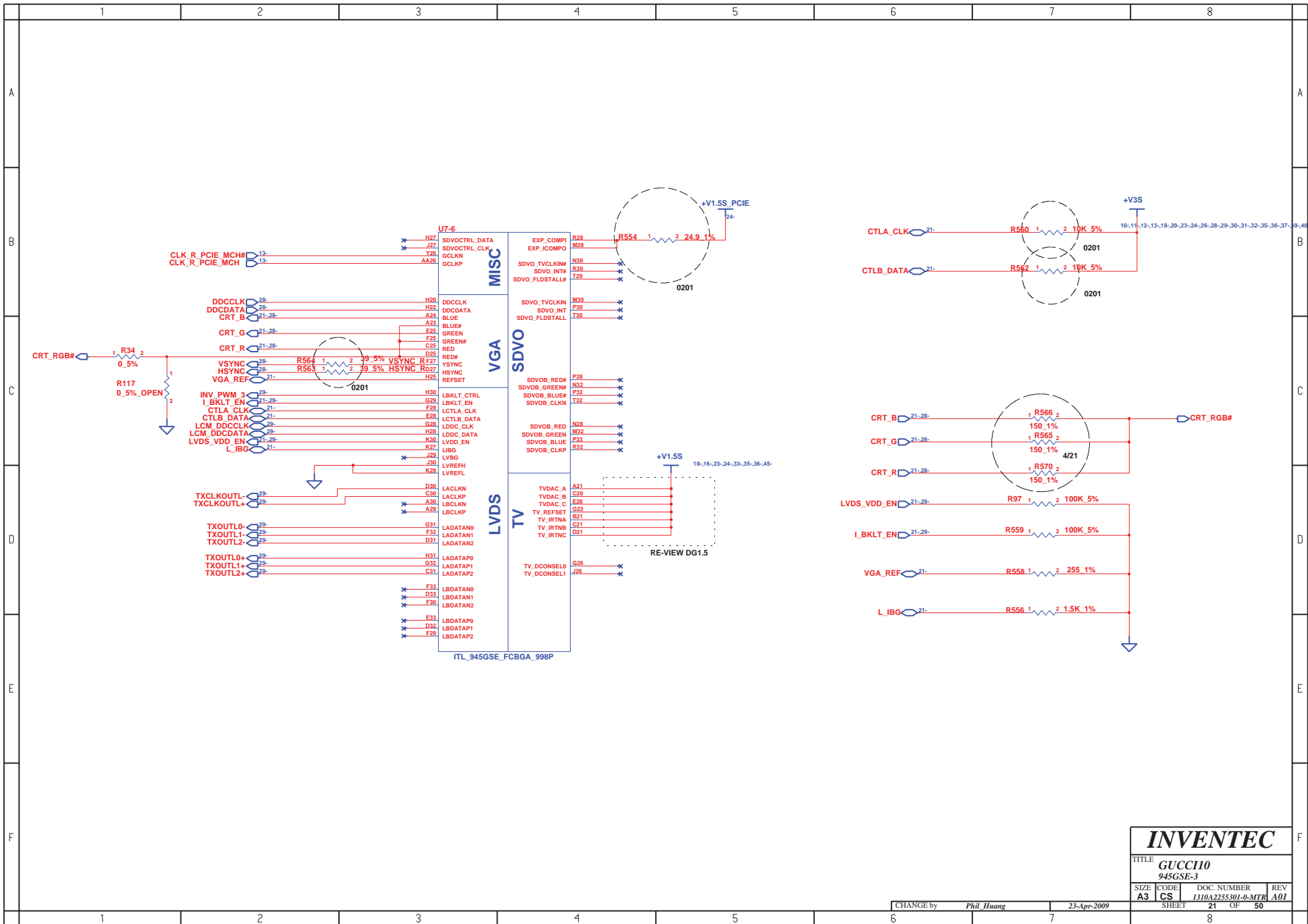

INVENTEC

TITLE **GUCCII0**
945GSE-3

SIZE	CODE	DOC. NUMBER	REV
A3	CS	1310A2255301-0-MTR	A01

CHANGE by *Phil Huang* 23-Apr-2009

SHEET 21 OF 50

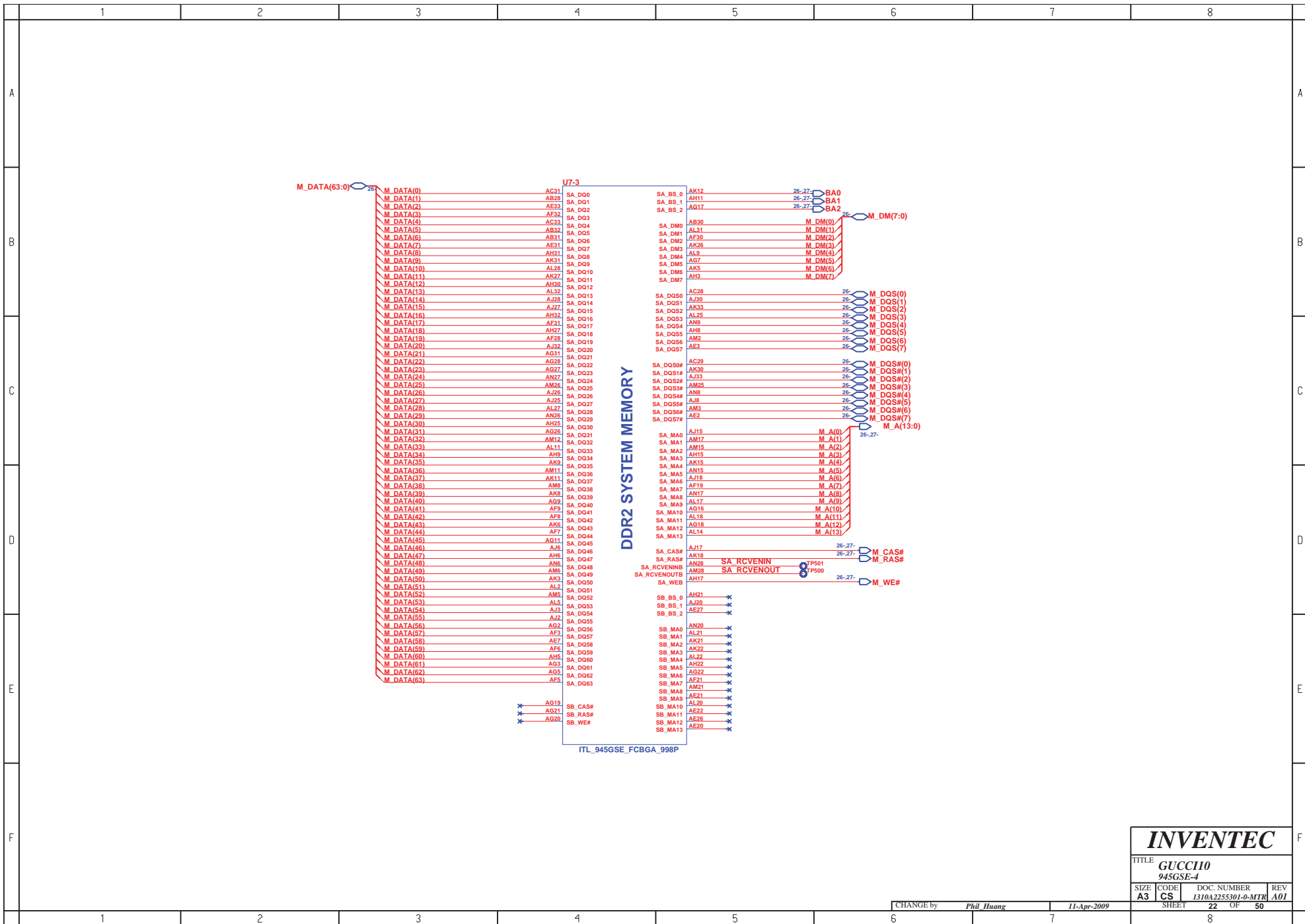

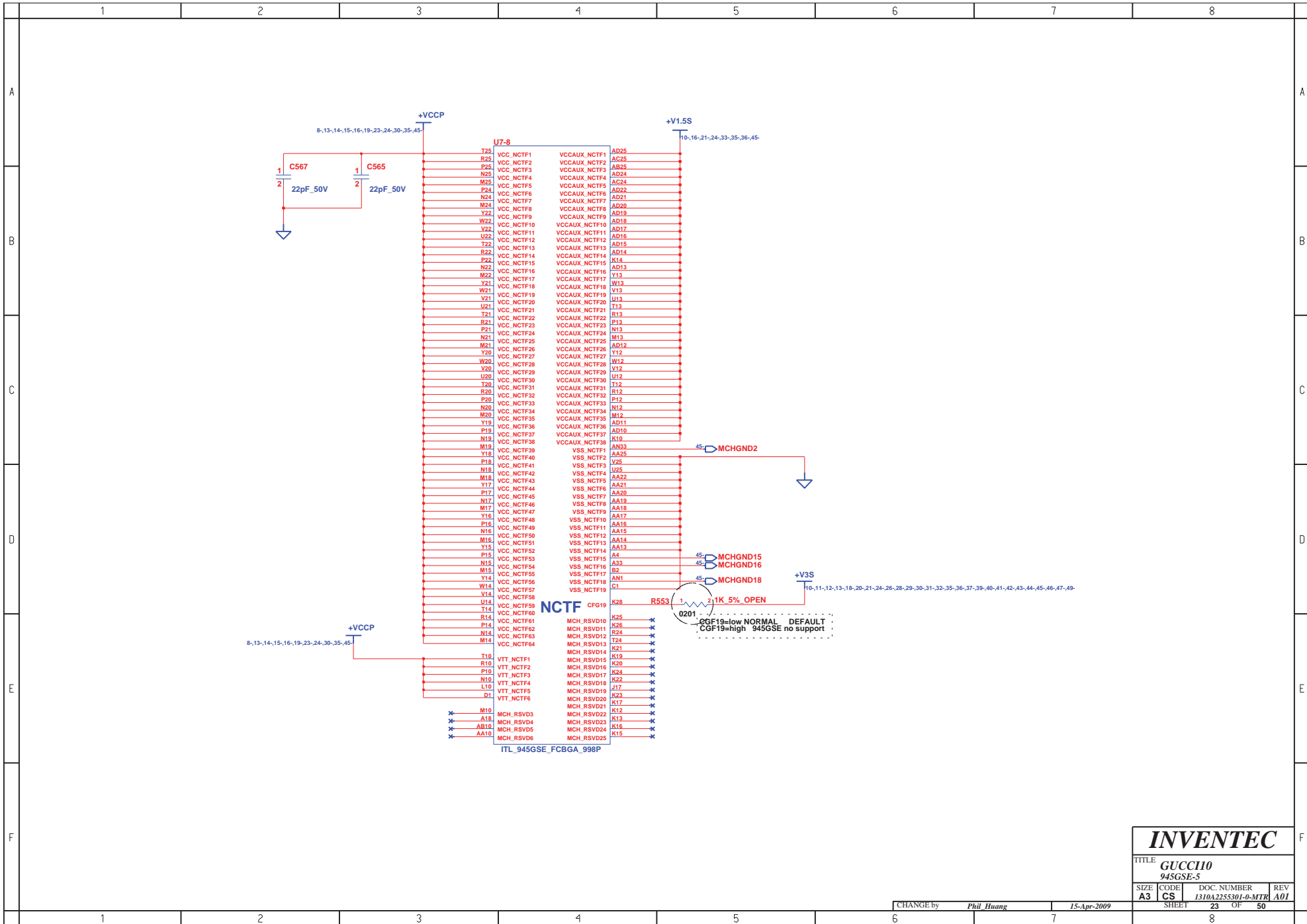

INVENTEC

TITLE
GUCC110
 945GSE-5

SIZE	CODE	DOC. NUMBER	REV
A3	CS	1310A2255301-0-MTR	A01

CHANGE by *Phil Huang* 15-Apr-2009

SHEET 23 OF 50

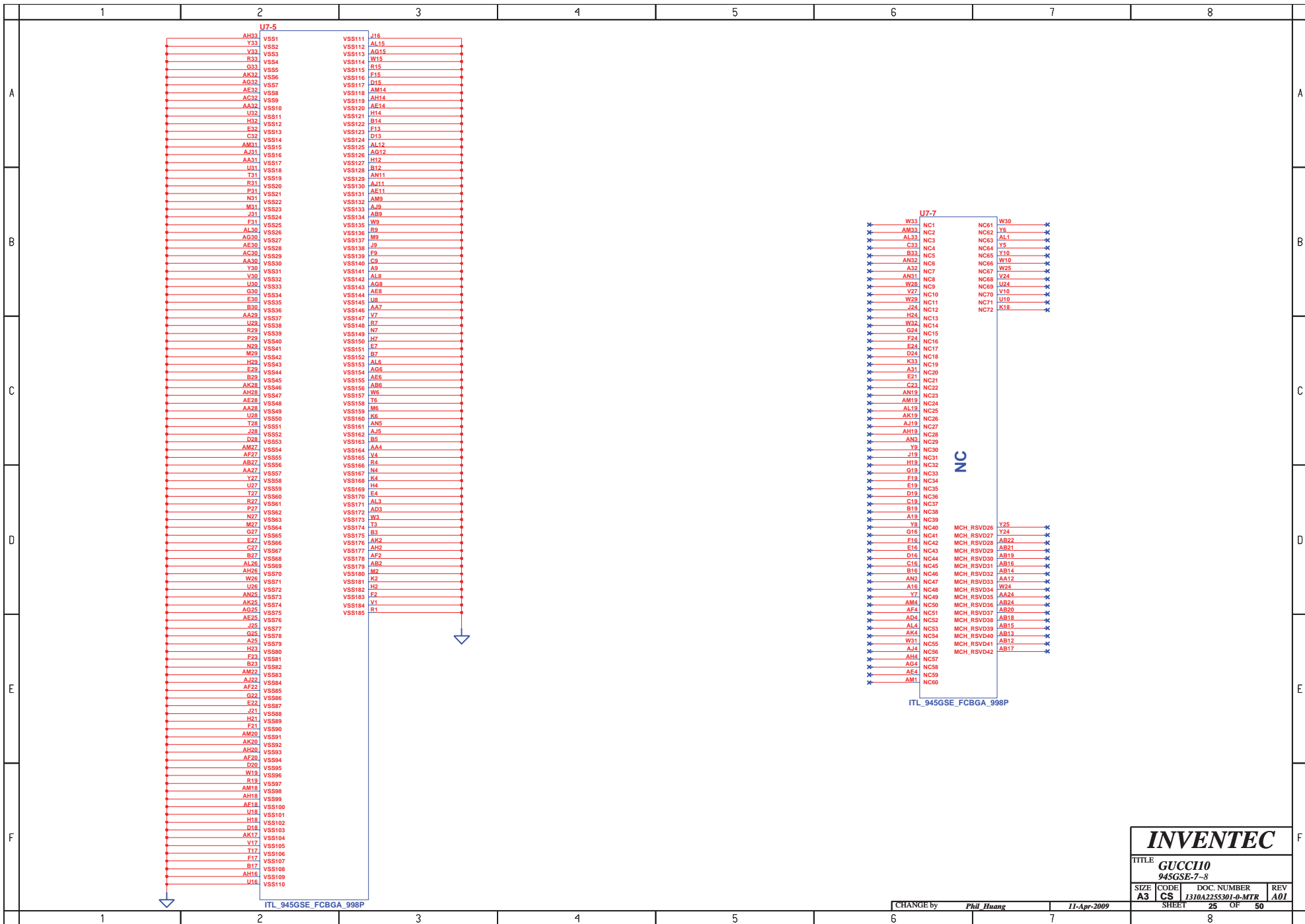

INVENTEC

TITLE
GUCCIO
 945GSE-7-8

SIZE A3	CODE CS	DOC. NUMBER 1310A2255301-0-MTR	REV A01
CHANGE by <i>Phil Huang</i>		11-Apr-2009	
SHEET 25		OF 50	

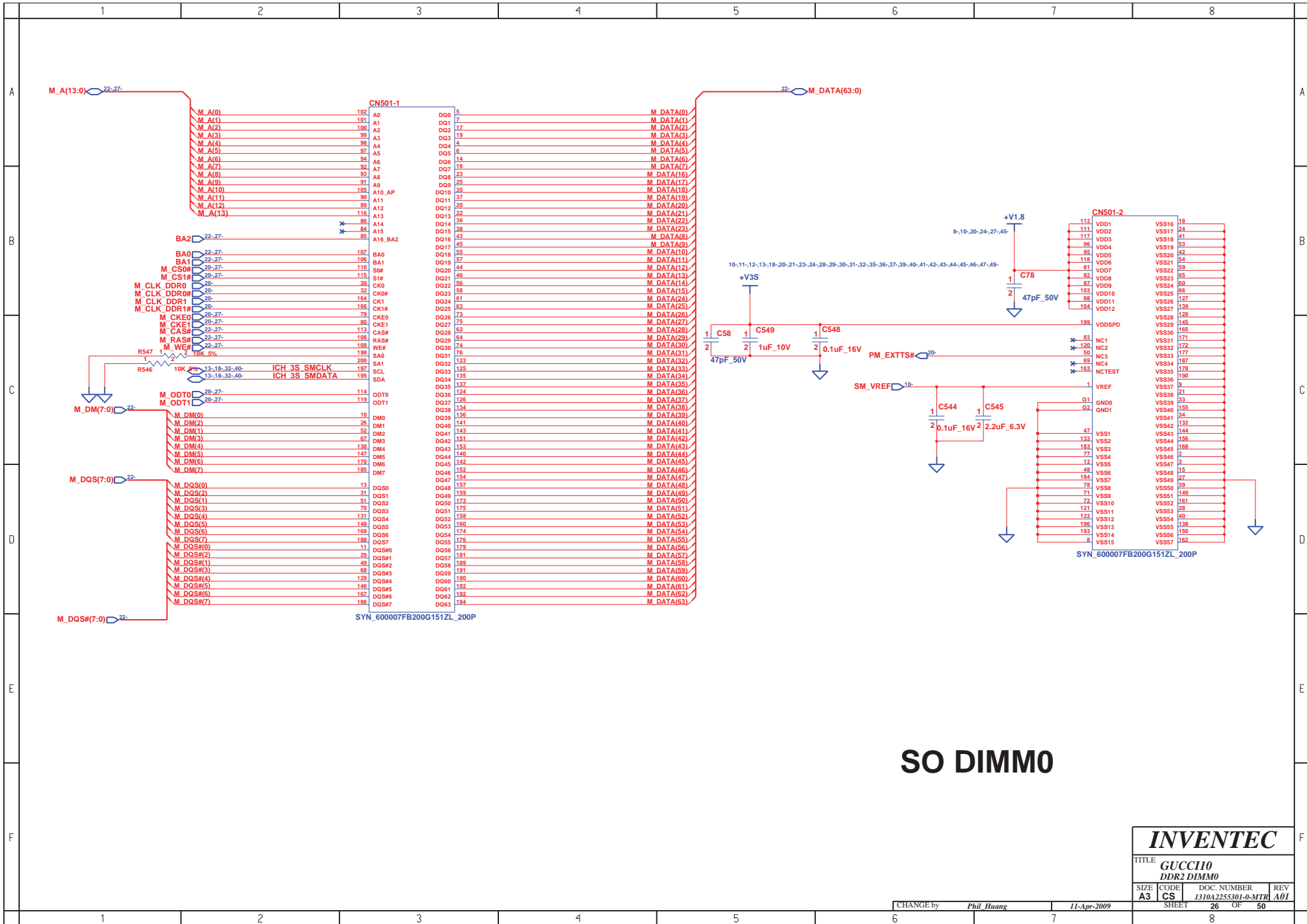

SO DIMM0

INVENTEC			
TITLE GUCC110 DDR2 DIMM0			
SIZE A3	CODE CS	DOC. NUMBER 1310A2255301-0-MTR	REV A01
CHANGE by <i>Phil Huang</i>		11-Apr-2009	
SHEET 26		OF 50	

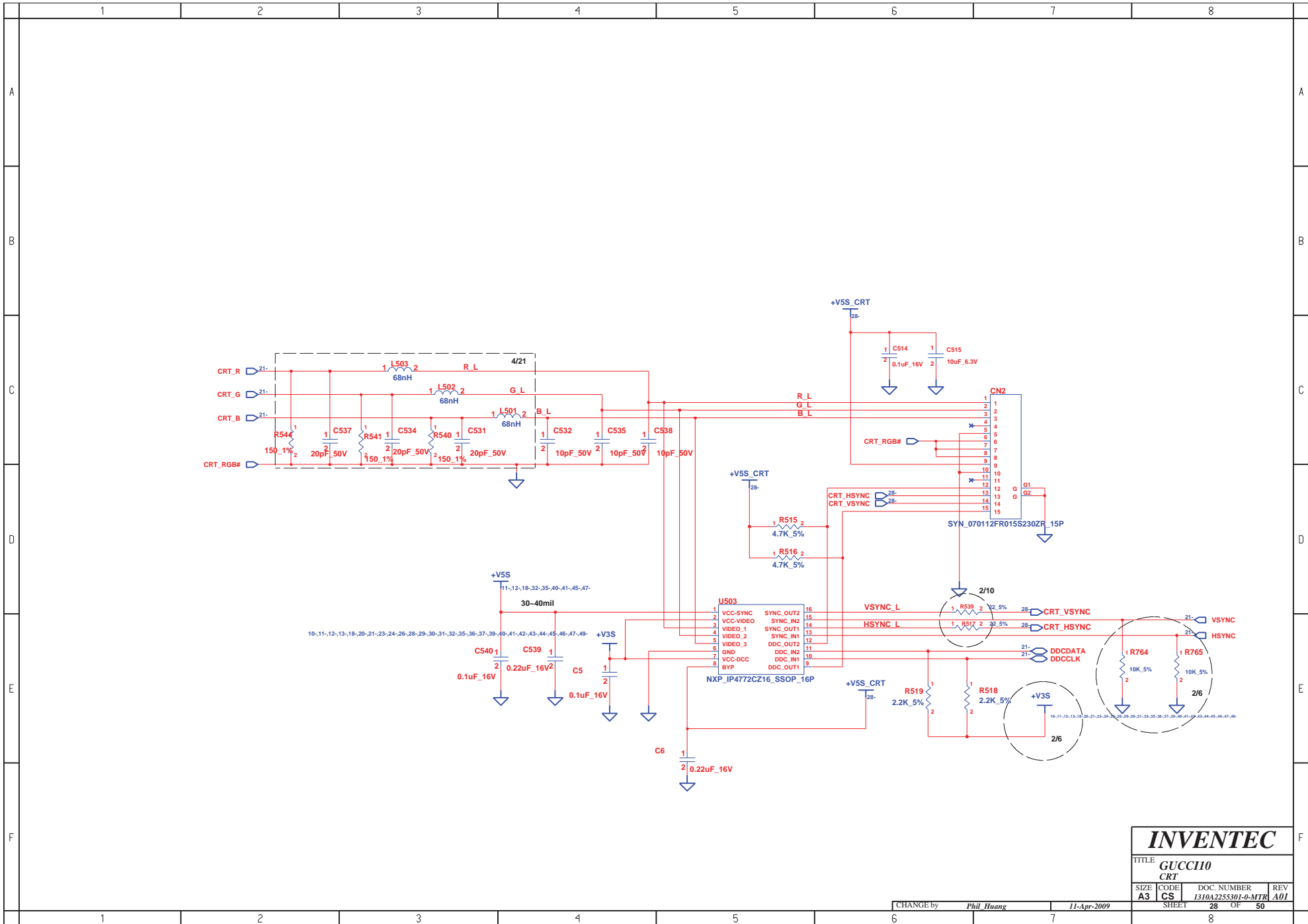

INVENTEC			
TITLE GUCC110			
CRT			
SIZE A3	CODE CS	DOC. NUMBER 1310A2255301-0-MTR	REV A01
CHANGE by <i>Phil Huang</i>		11-Apr-2009	
SHEET 28		OF 50	

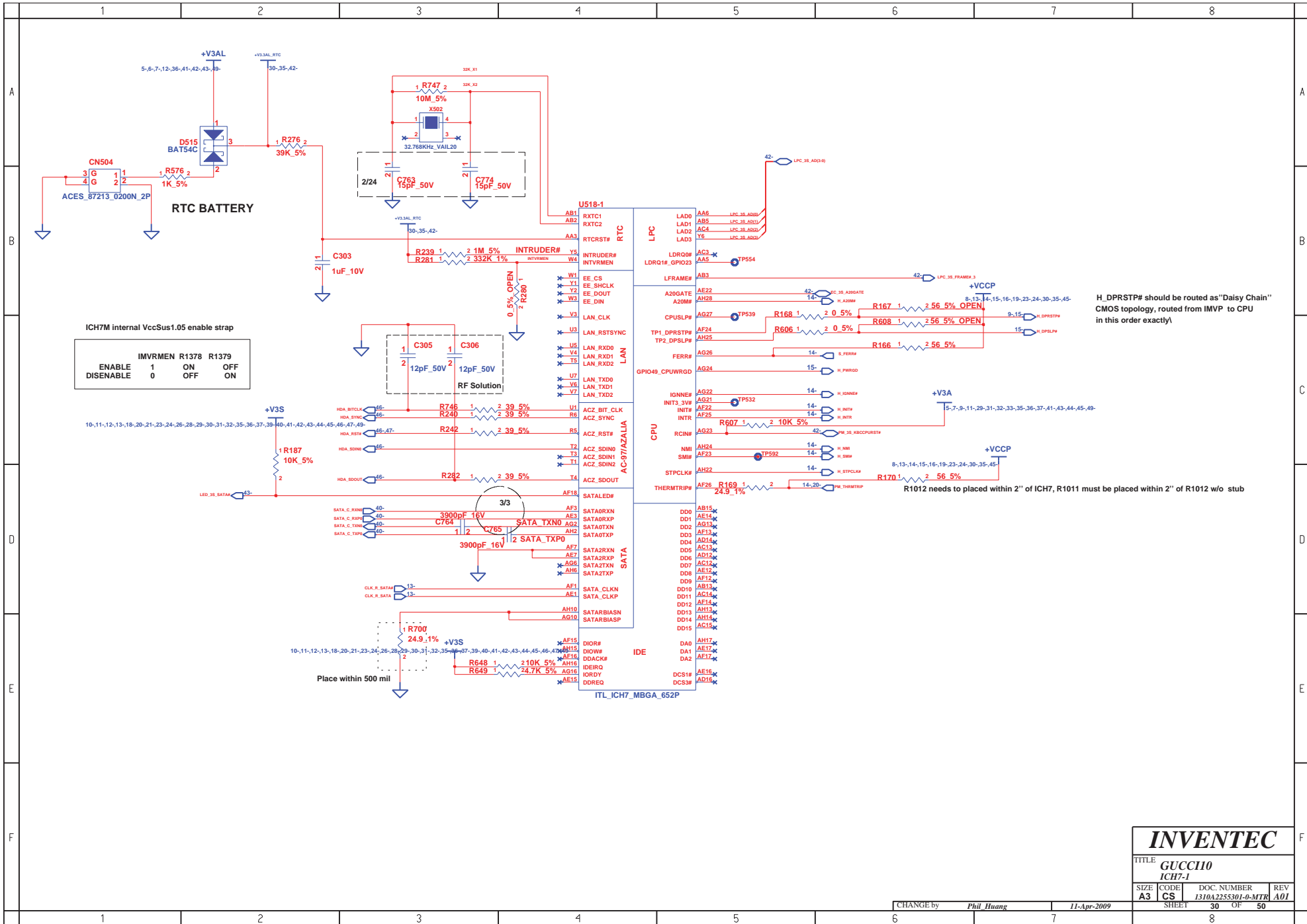

INVENTEC			
TITLE GUCCII0 ICH7-1			
SIZE A3	CODE CS	DOC. NUMBER 1310A2255301-0-MTR	REV A01
CHANGE by <i>Phil Huang</i>		11-Apr-2009	
SHEET 30		OF 50	

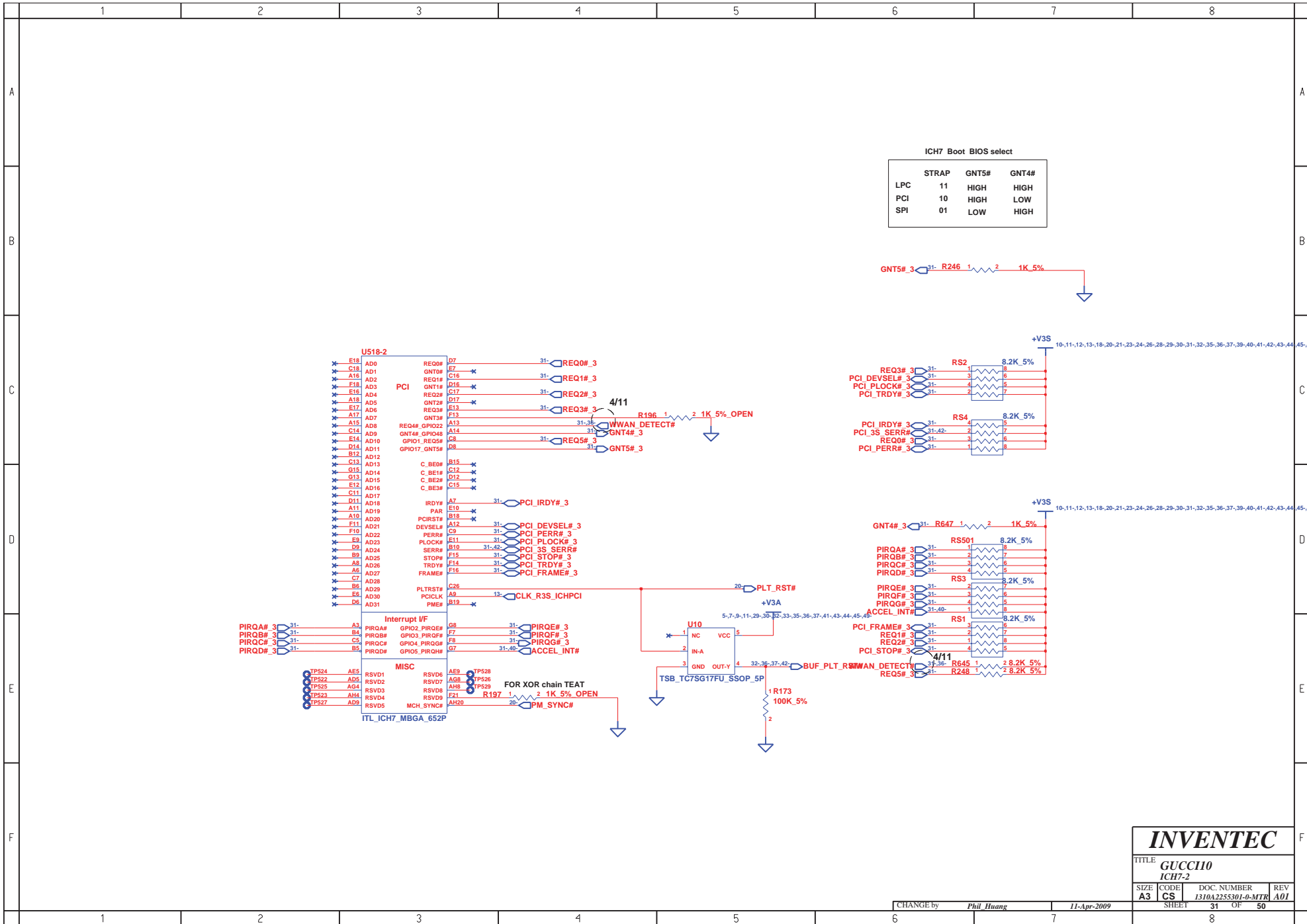

INVENTEC			
TITLE GUCC110 ICH7-2			
SIZE A3	CODE CS	DOC. NUMBER 1310A2255301-0-MTR	REV A01
CHANGE by <i>Phil Huang</i>		11-Apr-2009	
SHEET 31		OF 50	

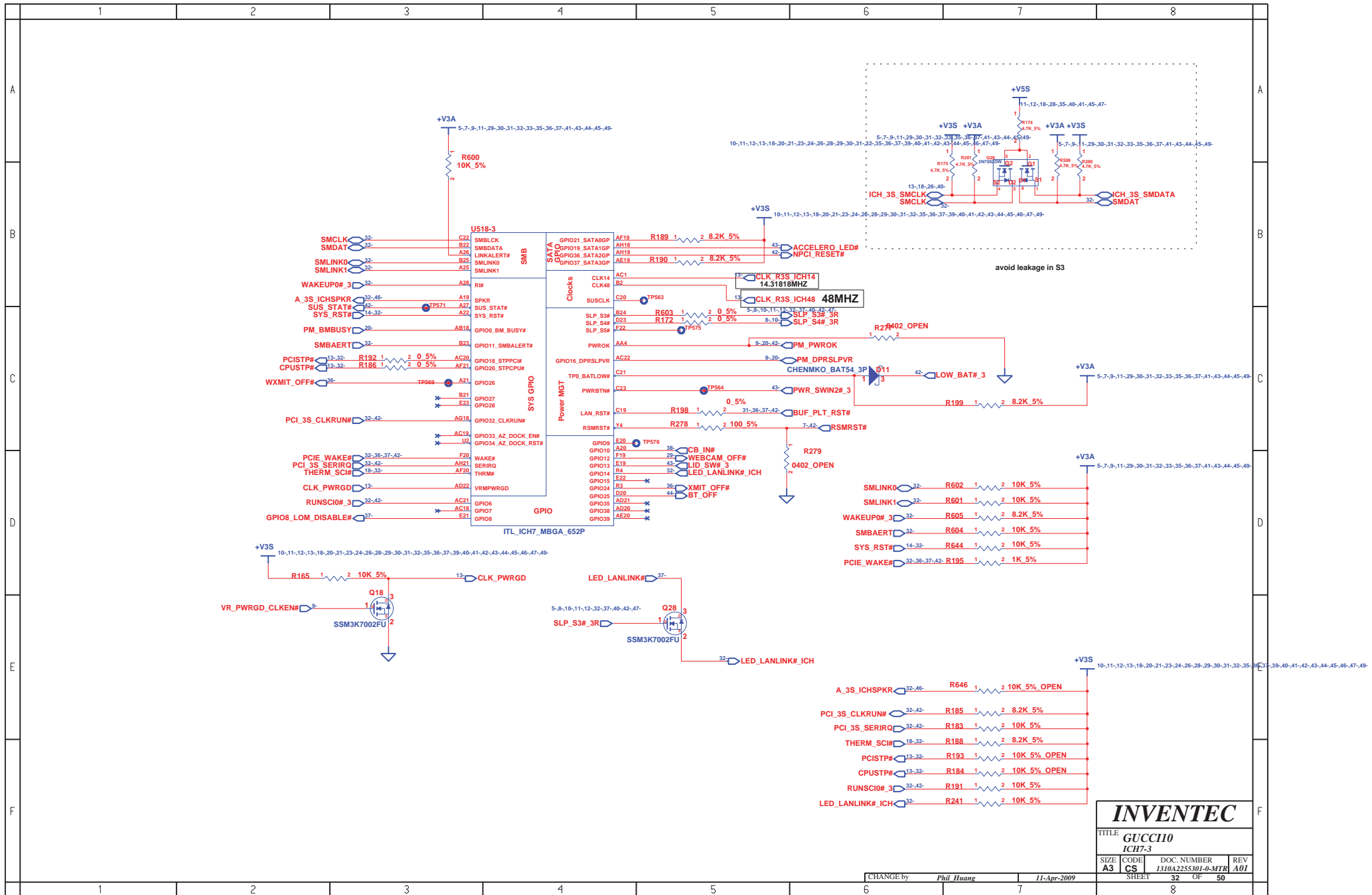

INVENTEC

TITLE: **GUC110**
ICH7-3

SIZE	CODE	DOC. NUMBER	REV
A3	CS	1310A225301-0-MTR	A01

CHANGE by *Phil Huang* 11-Apr-2009

SHEET 32 OF 50

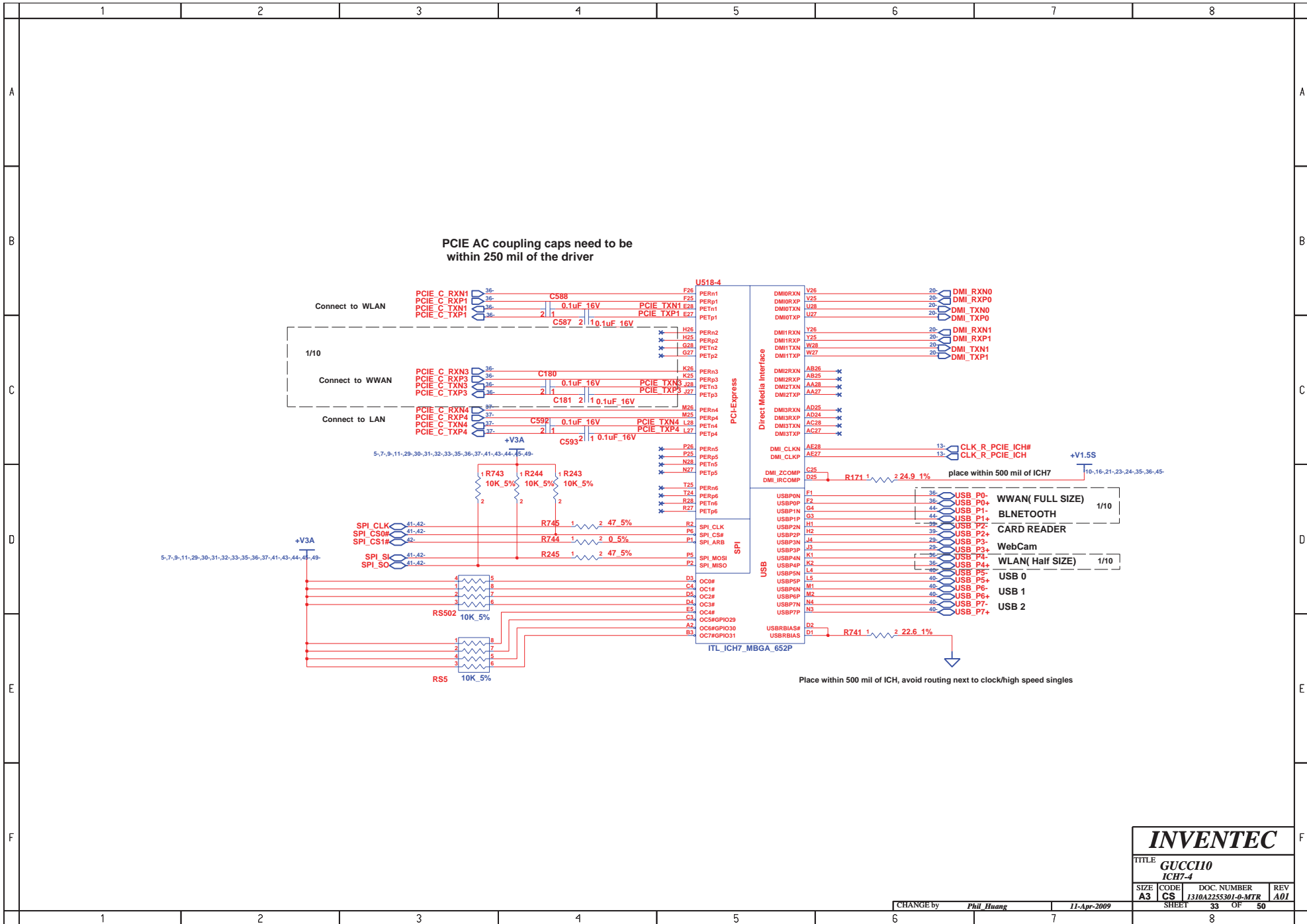

	1	2	3	4	5	6	7	8	
A									A
B									B
C									C
D									D
E									E
F									F

U519-5

A1	VSS1	VSS98	P28
A23	VSS2	VSS99	R1
B1	VSS3	VSS100	R11
B11	VSS4	VSS101	R12
B14	VSS5	VSS102	R13
B17	VSS6	VSS103	R14
B21	VSS7	VSS104	R15
B24	VSS8	VSS105	R16
B25	VSS9	VSS106	R17
B28	VSS10	VSS107	R18
C2	VSS11	VSS108	T6
C2	VSS12	VSS109	T12
C27	VSS13	VSS110	T13
D10	VSS14	VSS111	T14
D13	VSS15	VSS112	T15
D15	VSS16	VSS113	T16
D21	VSS17	VSS114	T17
D24	VSS18	VSS115	U4
E1	VSS19	VSS116	U12
E2	VSS20	VSS117	U13
E4	VSS21	VSS118	U14
E8	VSS22	VSS119	U15
E15	VSS23	VSS120	U16
F3	VSS24	VSS121	U17
F4	VSS25	VSS122	U24
F5	VSS26	VSS123	U25
F11	VSS27	VSS124	U26
F21	VSS28	VSS125	V2
F28	VSS29	VSS126	V13
G1	VSS30	VSS127	V15
G1	VSS31	VSS128	V24
G5	VSS32	VSS129	V27
G6	VSS33	VSS130	V28
G9	VSS34	VSS131	W6
G11	VSS35	VSS132	W24
G18	VSS36	VSS133	W25
G21	VSS37	VSS134	W26
G24	VSS38	VSS135	Y3
G25	VSS39	VSS136	Y24
G26	VSS40	VSS137	Y27
H3	VSS41	VSS138	Y28
H4	VSS42	VSS139	AA24
H5	VSS43	VSS140	AA25
H24	VSS44	VSS141	AA26
H27	VSS45	VSS142	AB4
H28	VSS46	VSS143	AB6
J1	VSS47	VSS144	AB11
J2	VSS48	VSS145	AB14
J5	VSS49	VSS146	AB15
J21	VSS50	VSS147	AB19
J25	VSS51	VSS148	AB21
J26	VSS52	VSS149	AB24
K21	VSS53	VSS150	AB27
K25	VSS54	VSS151	AB28
K26	VSS55	VSS152	AC2
L13	VSS56	VSS153	AC5
L15	VSS57	VSS154	AC9
L24	VSS58	VSS155	AC11
L25	VSS59	VSS156	AD1
L26	VSS60	VSS157	AD3
M1	VSS61	VSS158	AD4
M1	VSS62	VSS159	AD7
M5	VSS63	VSS160	AD8
M12	VSS64	VSS161	AD11
M13	VSS65	VSS162	AD15
M14	VSS66	VSS163	AD19
M15	VSS67	VSS164	AD23
M16	VSS68	VSS165	AE2
M17	VSS69	VSS166	AE4
M21	VSS70	VSS167	AE8
M21	VSS71	VSS168	AE11
M28	VSS72	VSS169	AE13
N1	VSS73	VSS170	AE18
N2	VSS74	VSS171	AE21
N5	VSS75	VSS172	AE24
N6	VSS76	VSS173	AE25
N11	VSS77	VSS174	AE2
N12	VSS78	VSS175	AF4
N13	VSS79	VSS176	AF8
N14	VSS80	VSS177	AF11
N15	VSS81	VSS178	AF27
N16	VSS82	VSS179	AF28
N17	VSS83	VSS180	AG1
N18	VSS84	VSS181	AG3
N21	VSS85	VSS182	AG7
N23	VSS86	VSS183	AG11
N26	VSS87	VSS184	AG14
P1	VSS88	VSS185	AG17
P1	VSS89	VSS186	AG20
P12	VSS90	VSS187	AG25
P13	VSS91	VSS188	AH1
P14	VSS92	VSS189	AH3
P15	VSS93	VSS190	AH7
P16	VSS94	VSS191	AH12
P17	VSS95	VSS192	AH23
P24	VSS96	VSS193	AH27
P27	VSS97	VSS194	

ITL_ICH7_MBGA_652P

INVENTEC			
TITLE GUCCIO			
ICH7-5			
SIZE	CODE	DOC. NUMBER	REV
A3	CS	1310A2253301-0-M1	R01
CHANGE by		11-Apr-2009	
SHEET		34 OF 50	

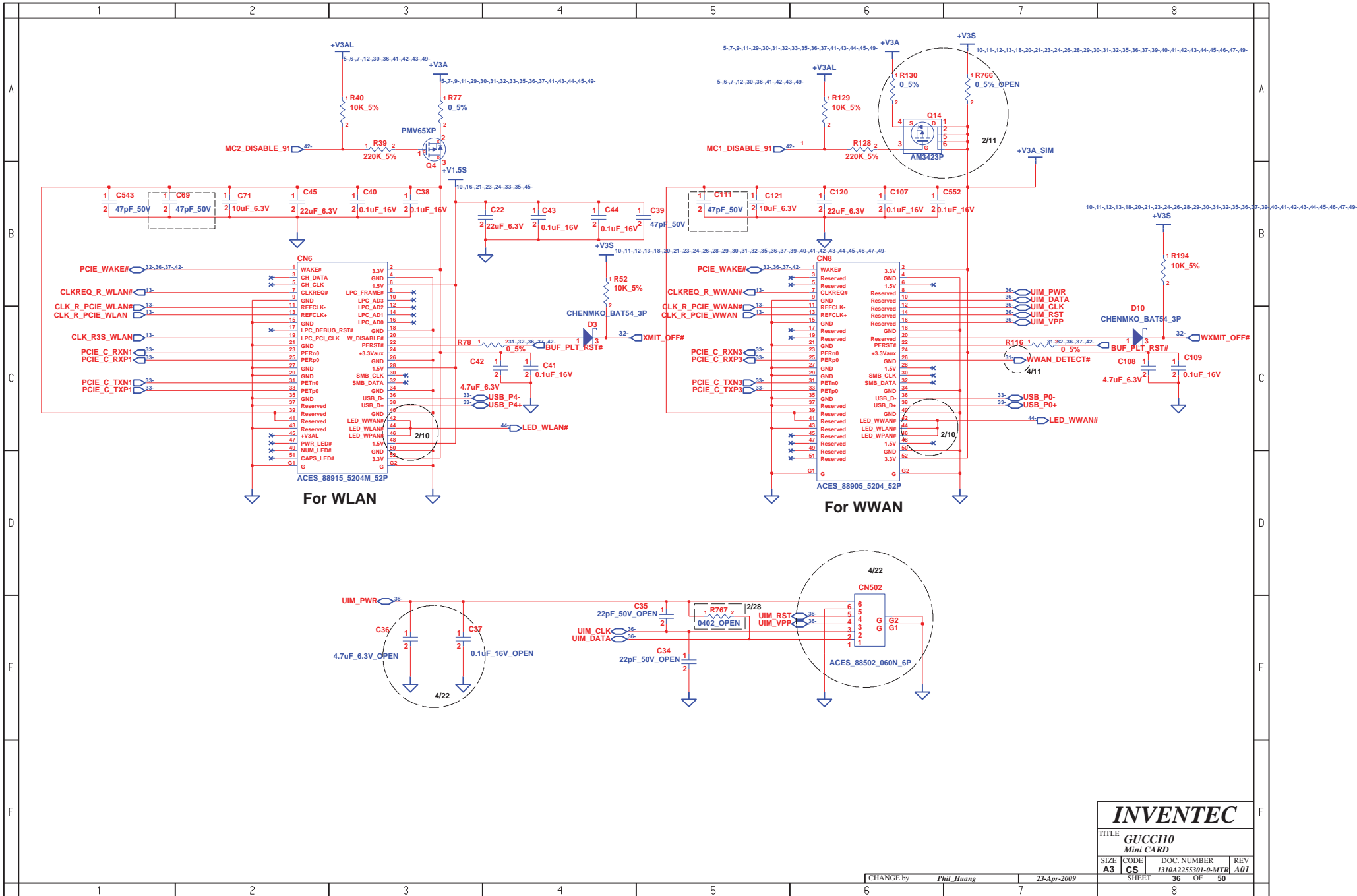

INVENTEC

TITLE: **GUCC110**
Mini CARD

SIZE	CODE	DOC. NUMBER	REV
A3	CS	1310A225S301-0-MTR	A01

CHANGE by: *Phil Huang* 23-Apr-2009

SHEET 36 OF 50

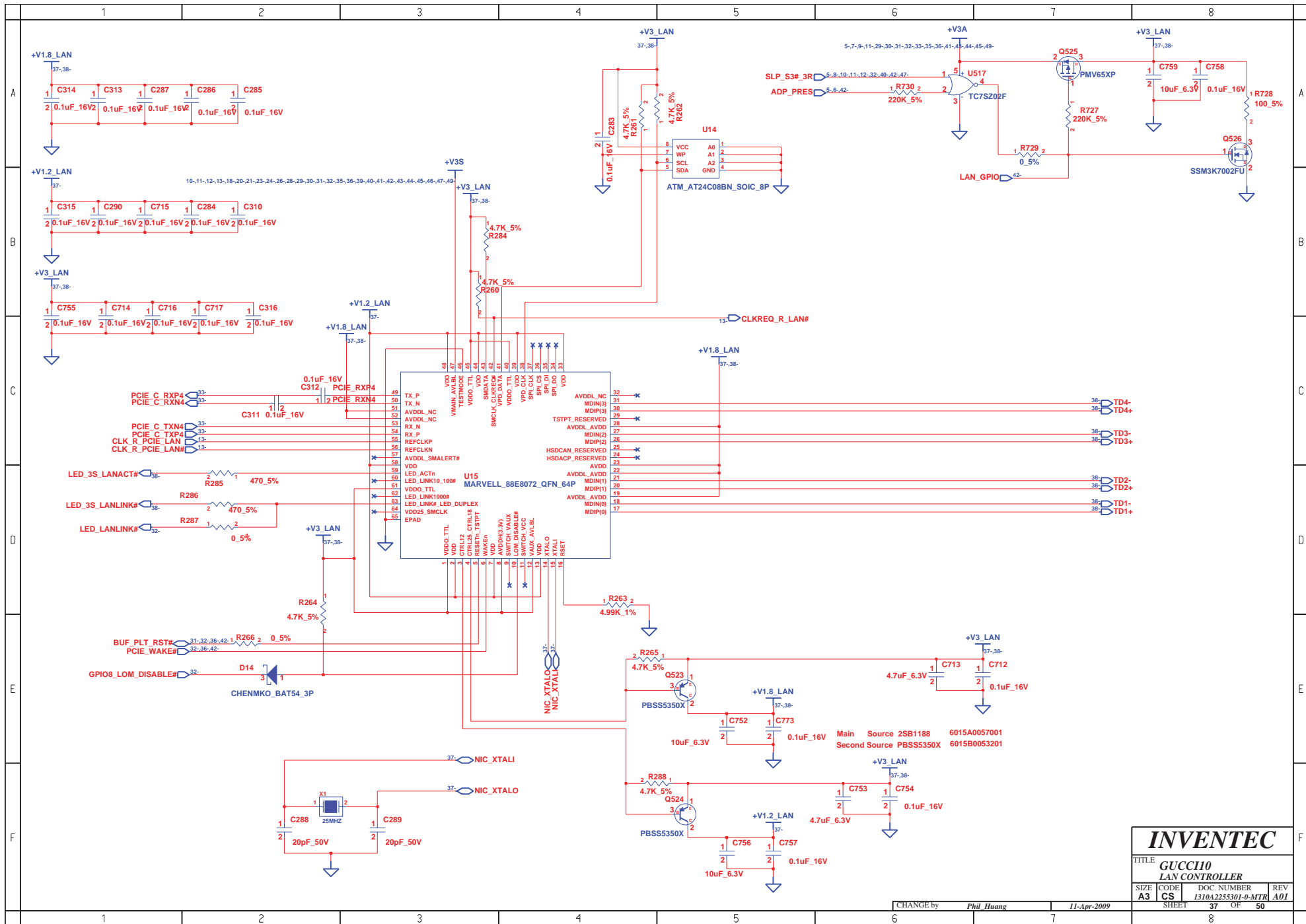

INVENTEC			
TITLE GUCCIO LAN CONTROLLER			
SIZE A3	CODE CS	DOC. NUMBER 1310A2255301-0-MTR	REV A01
CHANGE by <i>Phil Huang</i>		11-Apr-2009	
SHEET 37		OF 50	

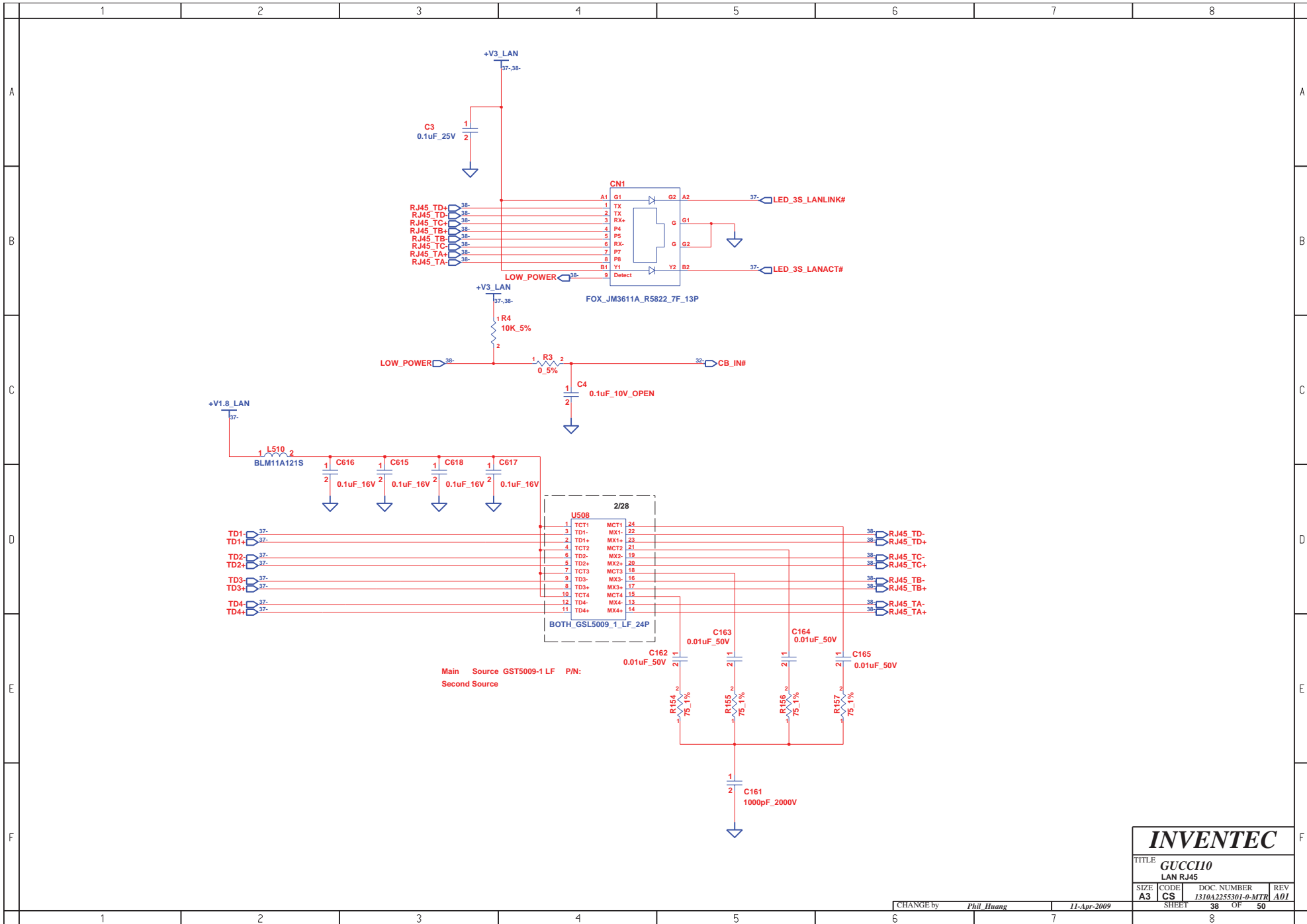

INVENTEC			
TITLE GUCC110 LAN RJ45			
SIZE A3	CODE CS	DOC. NUMBER 1310A2255301-0-MTR	REV A01
CHANGE by <i>Phil Huang</i>		11-Apr-2009	
SHEET 38		OF 50	

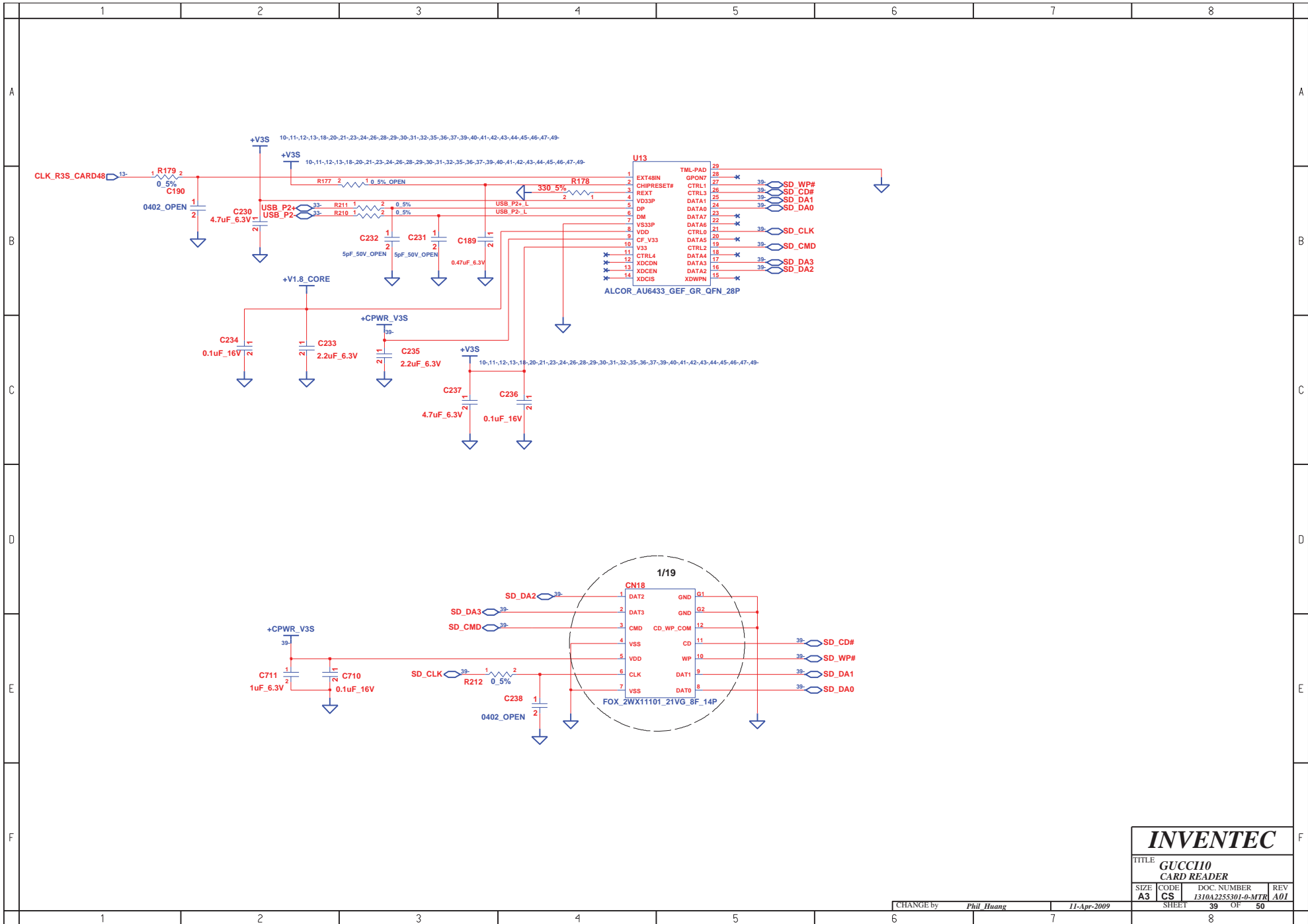

INVENTEC

TITLE GUCC110 CARD READER			
SIZE A3	CODE CS	DOC. NUMBER 1310A2255301-0-MTR	REV A01
CHANGE by <i>Phil Huang</i>		11-Apr-2009	
SHEET 39		OF 50	

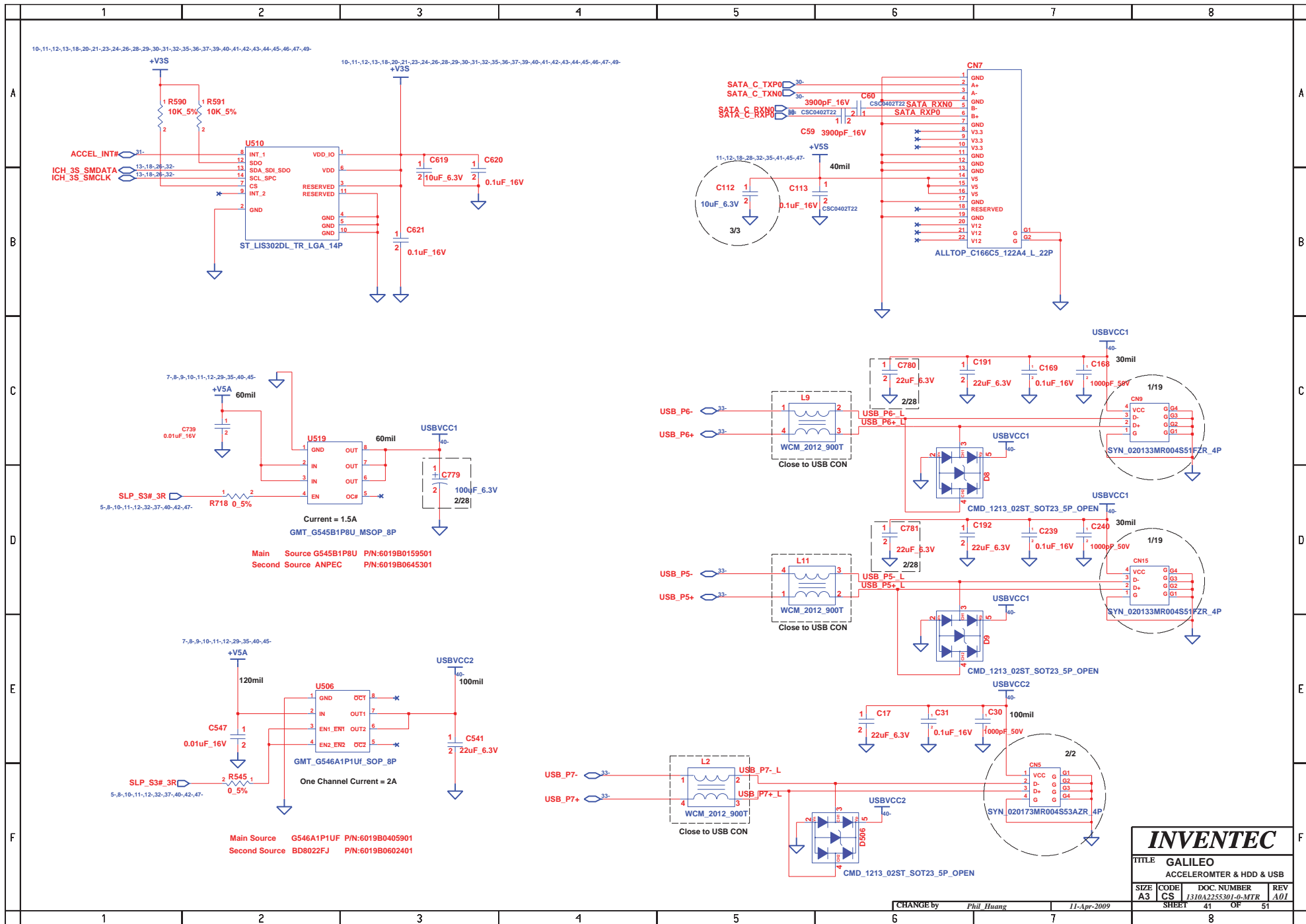

INVENTEC			
TITLE GALILEO ACCELEROMETER & HDD & USB			
SIZE A3	CODE CS	DOC. NUMBER 1310A2255301-0-MTR	REV A01
CHANGE by Phil Huang		11-Apr-2009	
SHEET 41		OF 51	

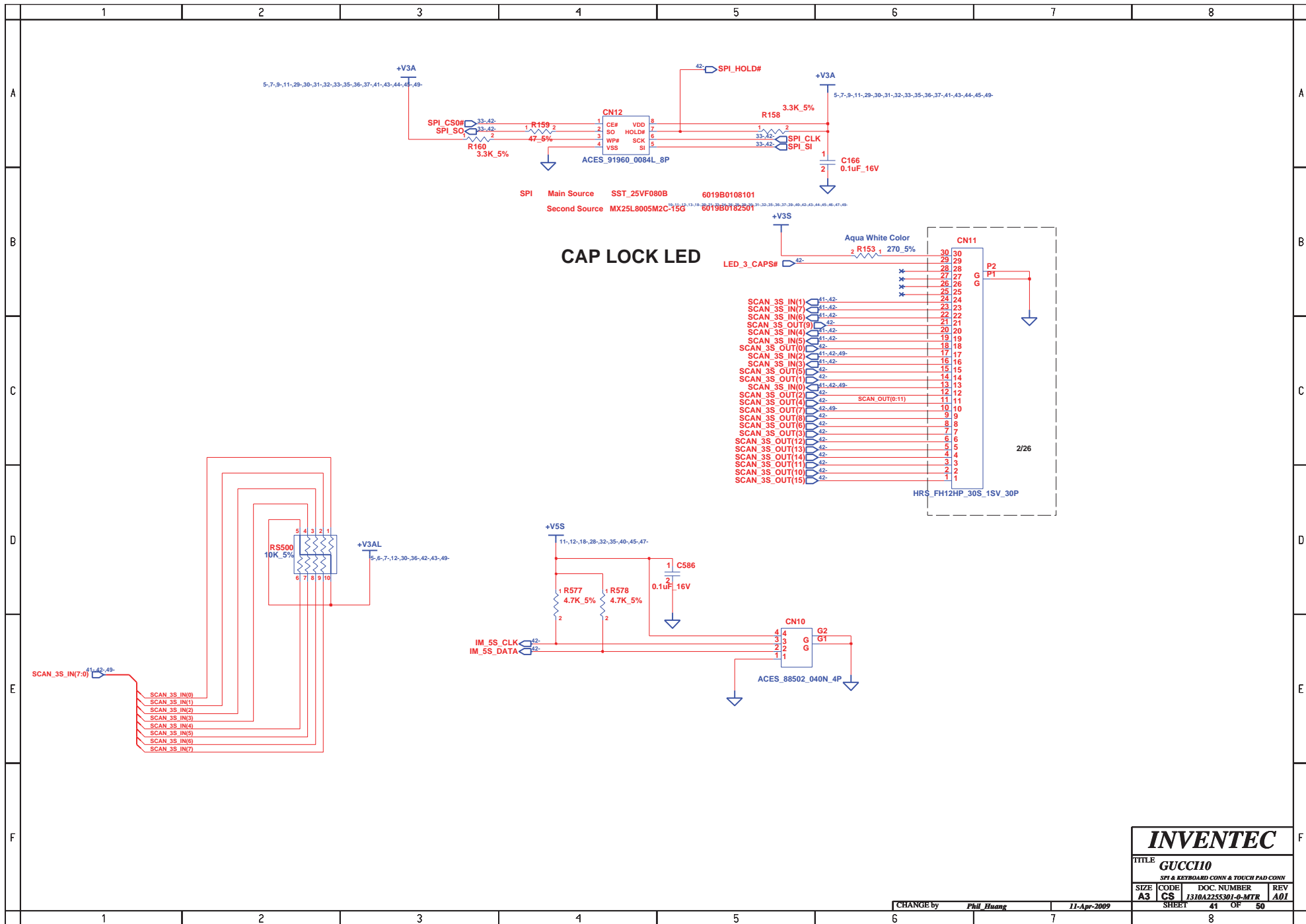

INVENTEC			
TITLE GUCCIO			
SPI & KEYBOARD CONN & TOUCH PAD CONN			
SIZE A3	CODE CS	DOC. NUMBER 1310A2255301-0-MTR	REV A01
CHANGE by Phil Huang		11-Apr-2009	
SHEET 41		OF 50	

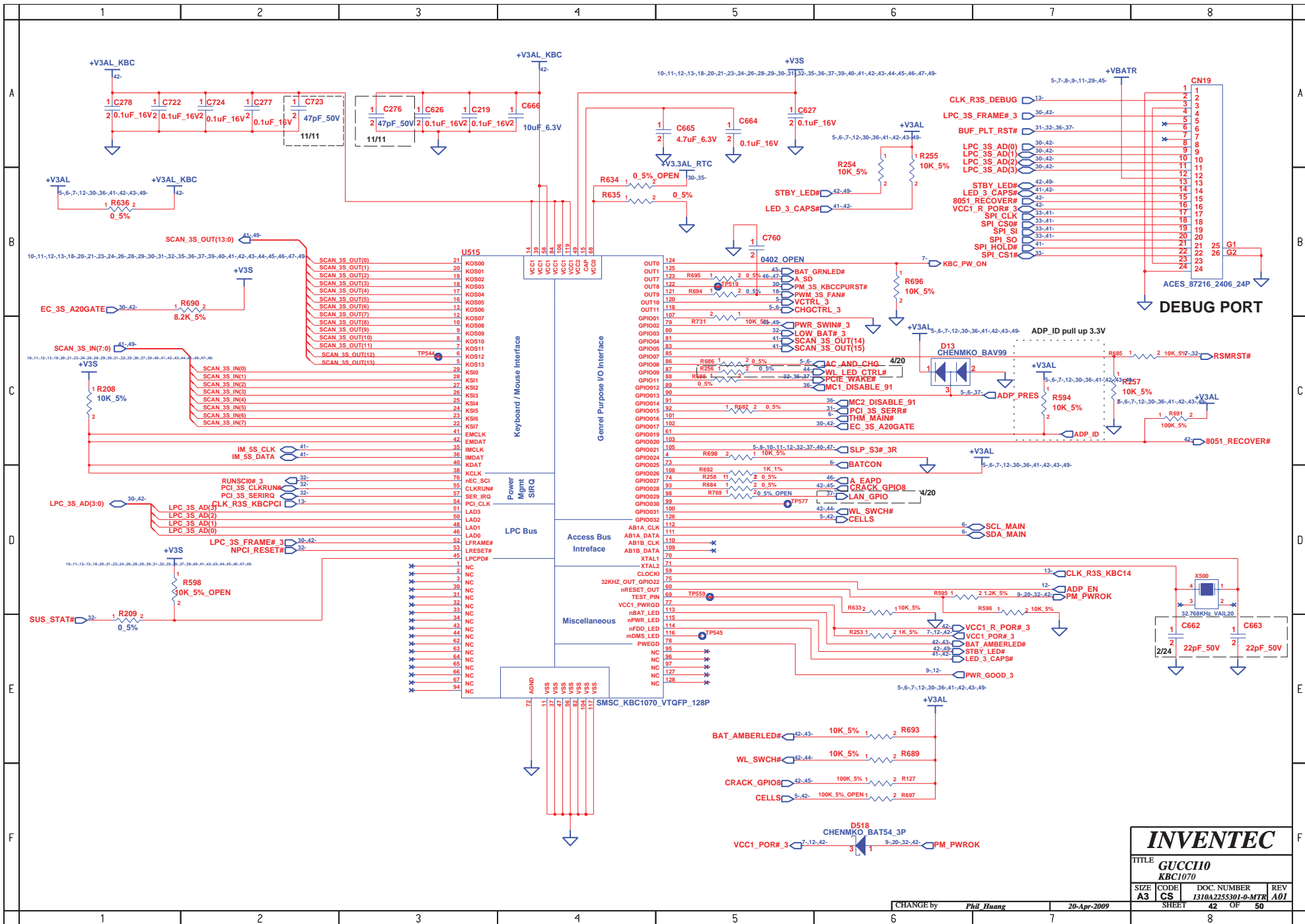

INVENTEC			
TITLE GUCC110 KBC1070			
SIZE A3	CODE CS	DOC. NUMBER 1310A2255301-0-MTR	REV A01
CHANGE by <i>Phil Huang</i>		20-Apr-2009	
SHEET 42		OF 50	

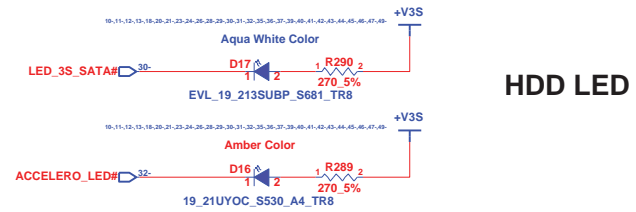
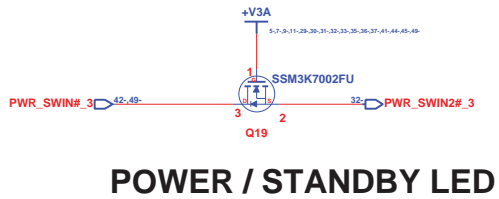
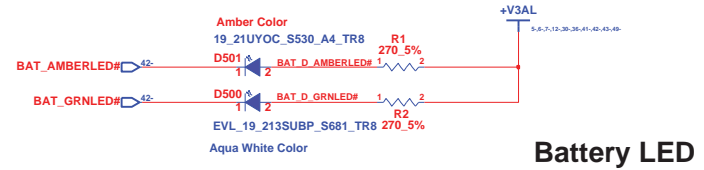
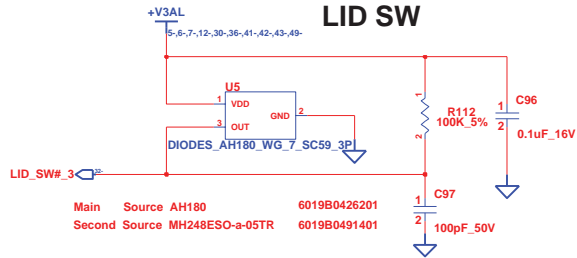

INVENTEC			
TITLE GUCCI10			
LID & LED & POWER SWITCH			
SIZE A3	CODE CS	DOC. NUMBER 1310A2255301-0-MTR	REV A01
CHANGE by <i>Phil Huang</i>		11-Apr-2009	
SHEET 44		OF 50	

BLUETOOTH

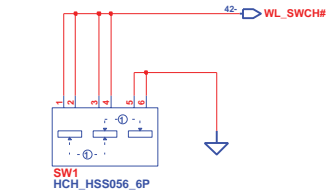
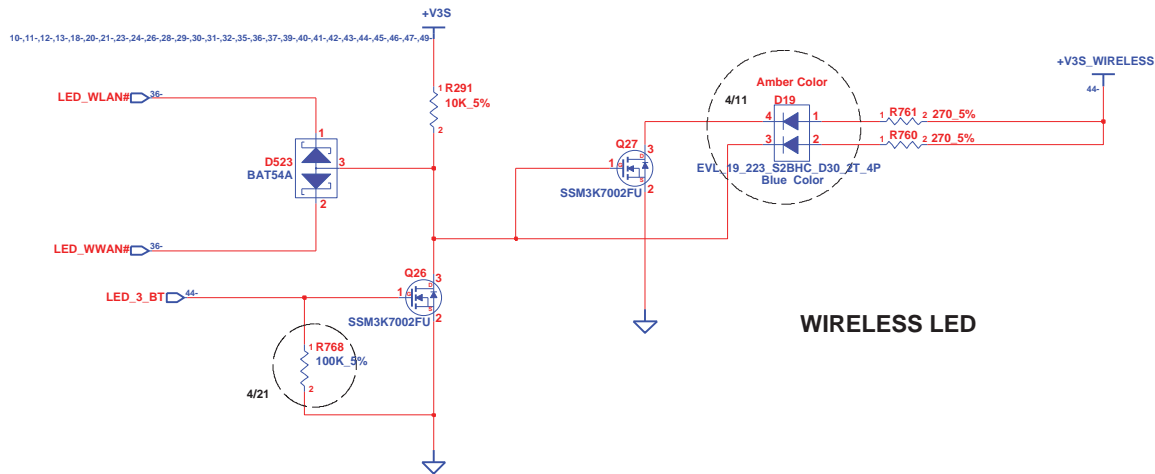
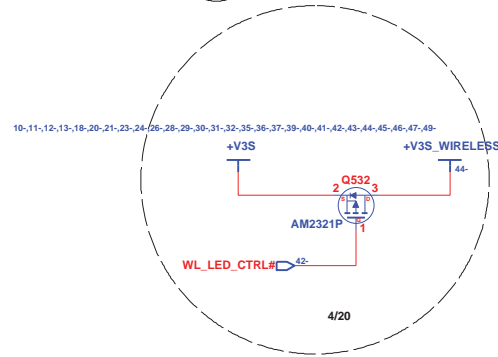
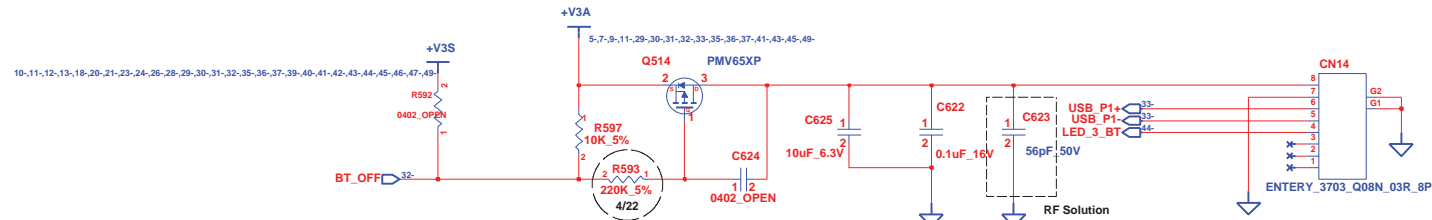

WIRELESS LED

WIRELESS SWITCH

INVENTEC

TITLE **GUCCI10**
BLUETOOTH & WIRELESS SWITCH

SIZE A3	CODE CS	DOC. NUMBER 1310A2255301-0-MTR	REV A01
----------------	----------------	---------------------------------------	----------------

CHANGE by *Phil Huang* 11-Apr-2009

SHEET 45 OF 50

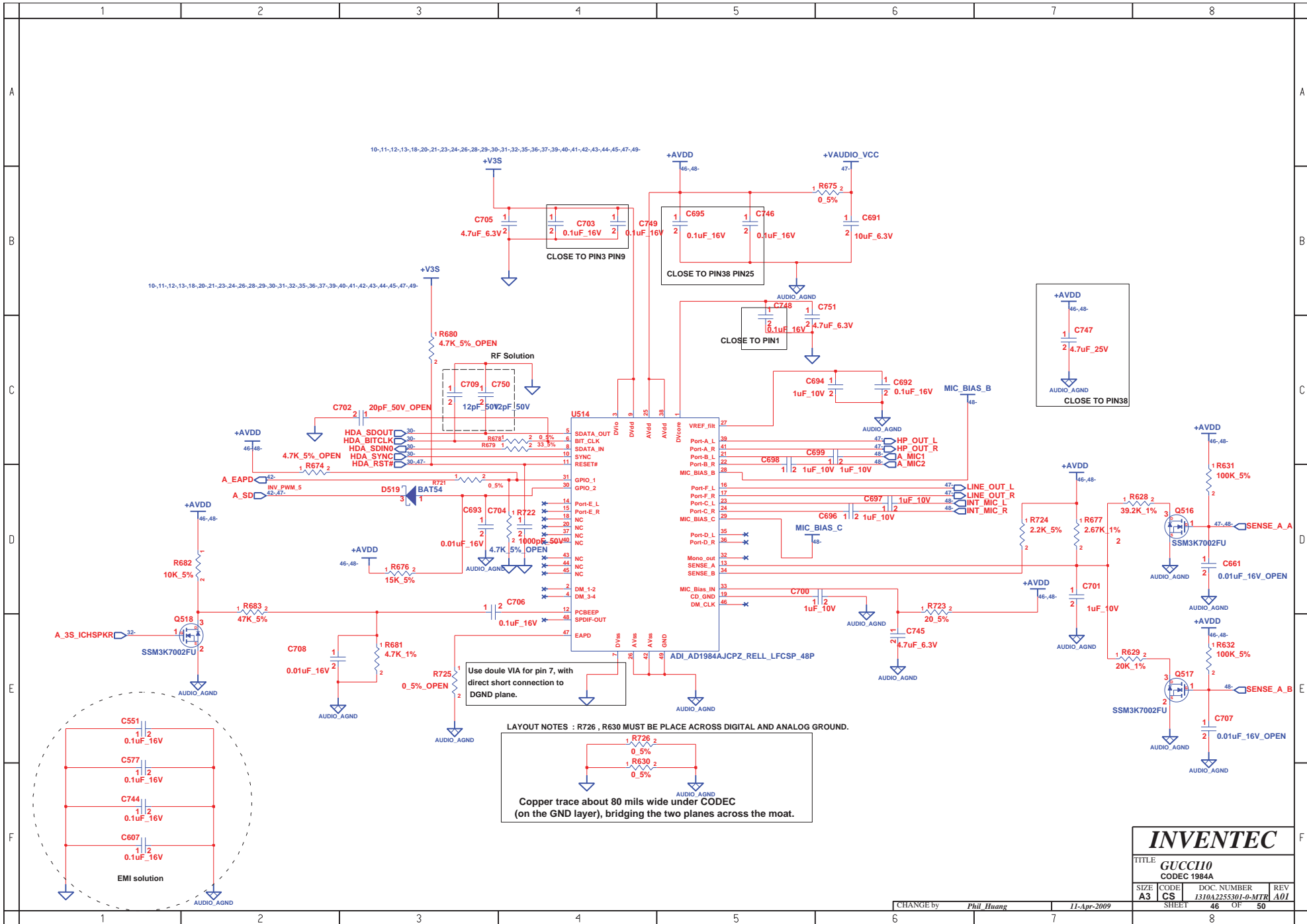

LAYOUT NOTES : R726, R630 MUST BE PLACE ACROSS DIGITAL AND ANALOG GROUND.

Copper trace about 80 mils wide under CODEC (on the GND layer), bridging the two planes across the moat.

INVENTEC			
TITLE GUCC110 CODEC 1984A			
SIZE A3	CODE CS	DOC NUMBER 1310A2255301-0-MTR	REV A01
CHANGE by Phil Huang		11-Apr-2009	
SHEET 46		OF 50	

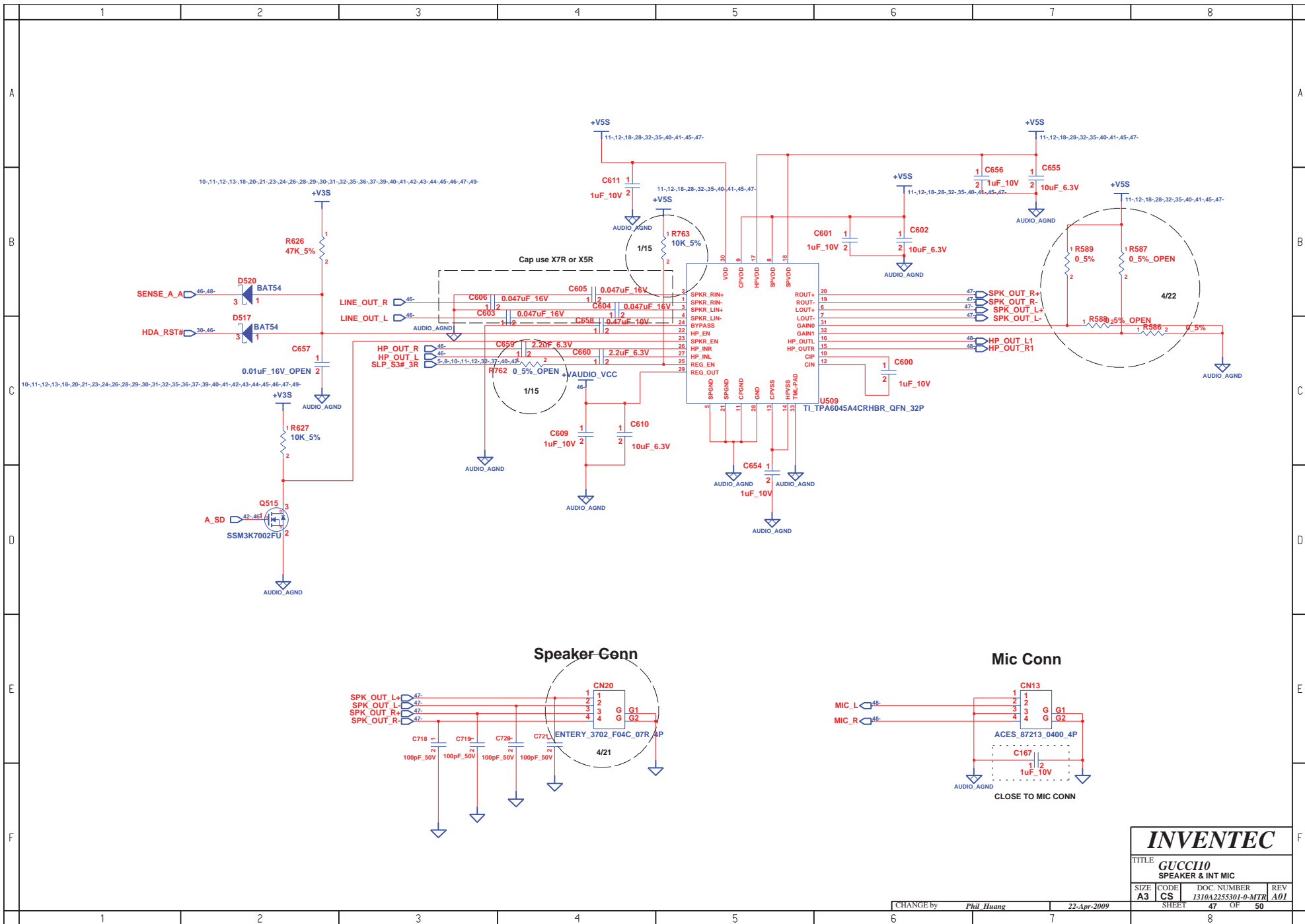

INVENTEC			
TITLE GUCCII0 SPEAKER & INT MIC			
SIZE A3	CODE CS	DOC NUMBER 1310A2255301-0-MTR	REV A01
CHANGE by <i>Phil Huang</i>		22-Apr-2009	
SHEET 47		OF 50	

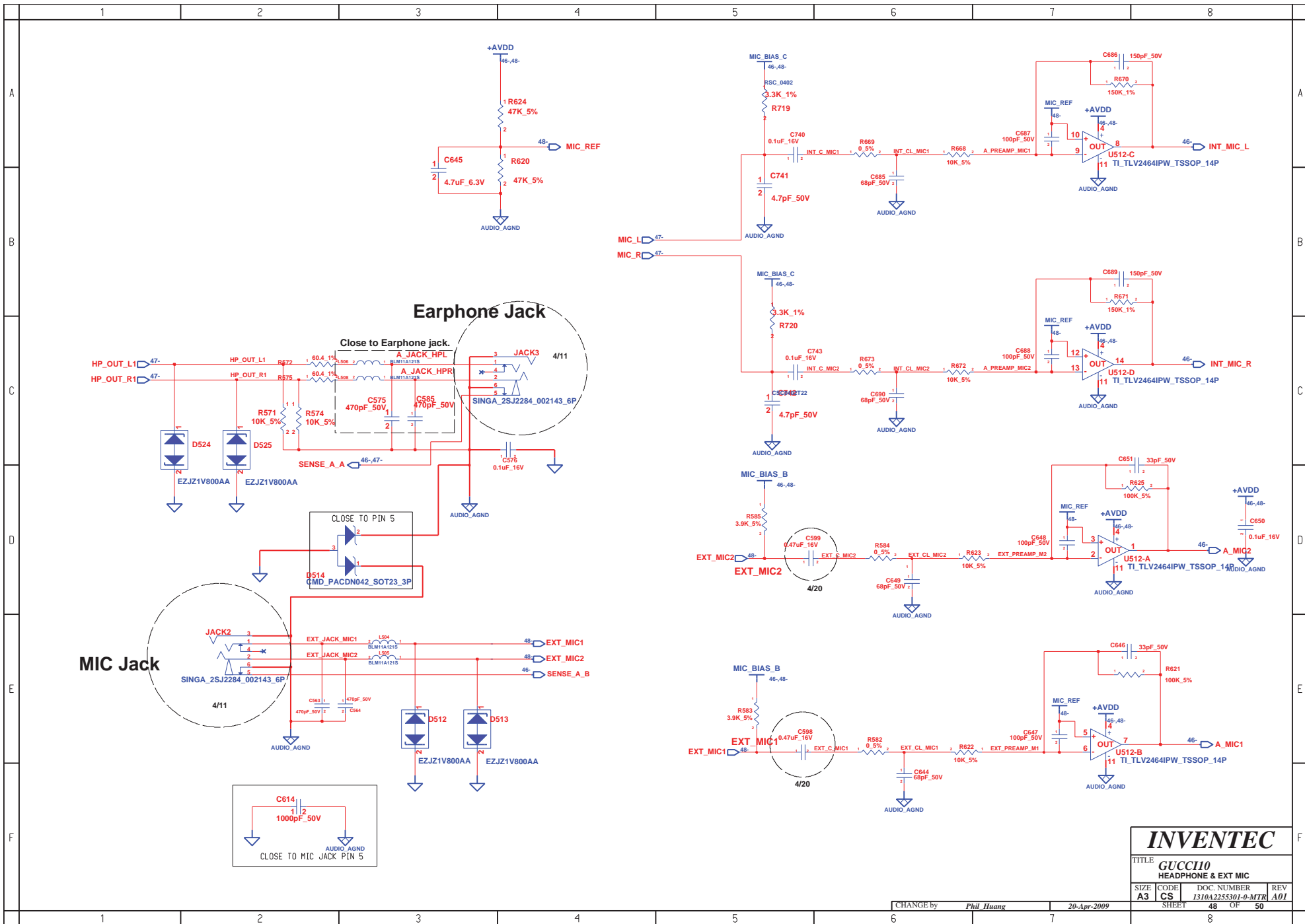

INVENTEC			
TITLE GUCCII0 HEADPHONE & EXT MIC			
SIZE A3	CODE CS	DOC. NUMBER 1310A2255301-0-MTR	REV A01
CHANGE by <i>Phil Huang</i>		20-Apr-2009	
		SHEET 48 OF 50	

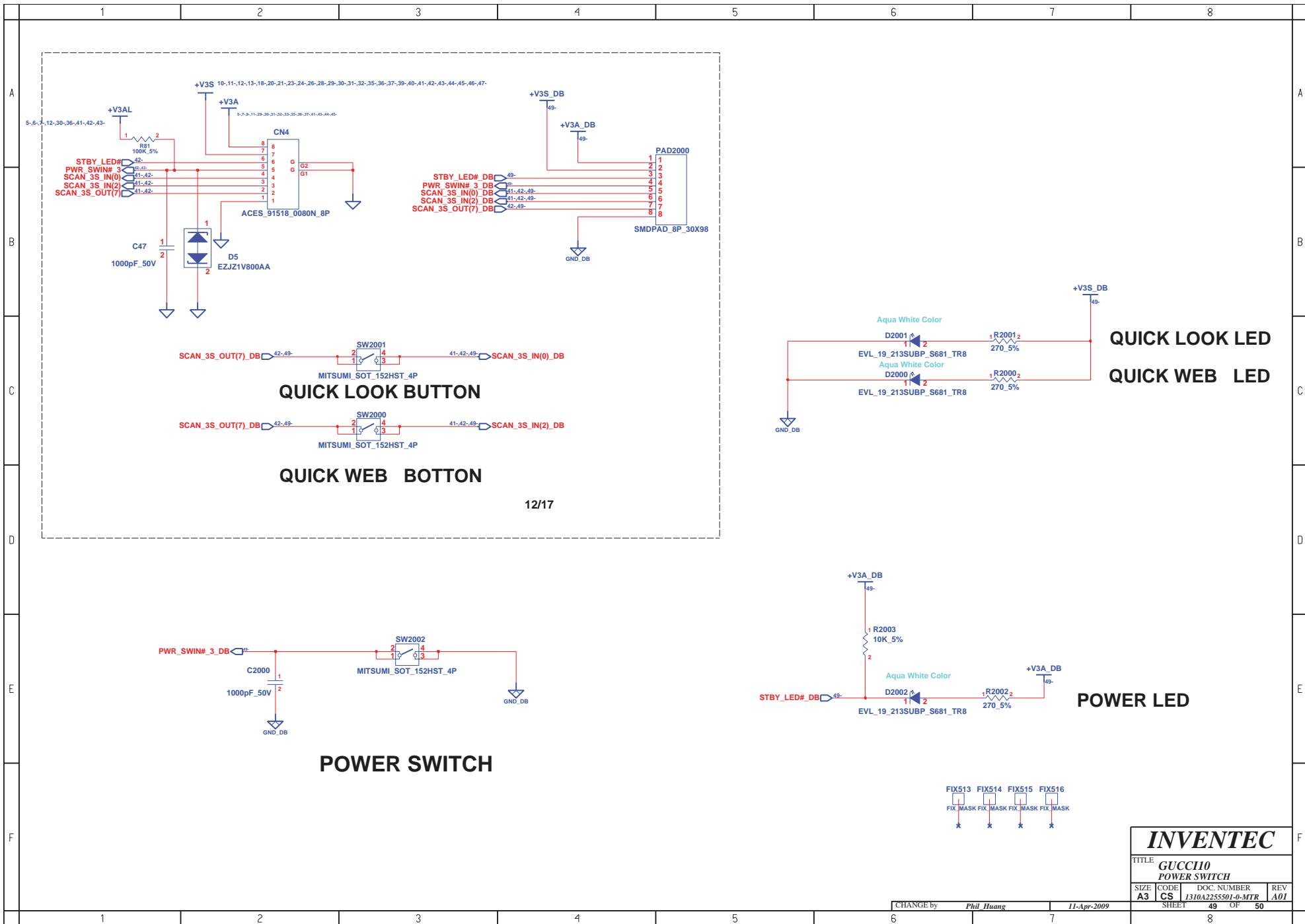

12/17

FIX513
FIX514
FIX515
FIX516
FIX MASK FIX MASK FIX MASK FIX MASK

INVENTEC			
TITLE GUCCI10 POWER SWITCH			
SIZE A3	CODE CS	DOC. NUMBER 1310A2255501-0-MTR	REV A01
CHANGE by <i>Phil Huang</i>		11-Apr-2009	
SHEET 49		OF 50	

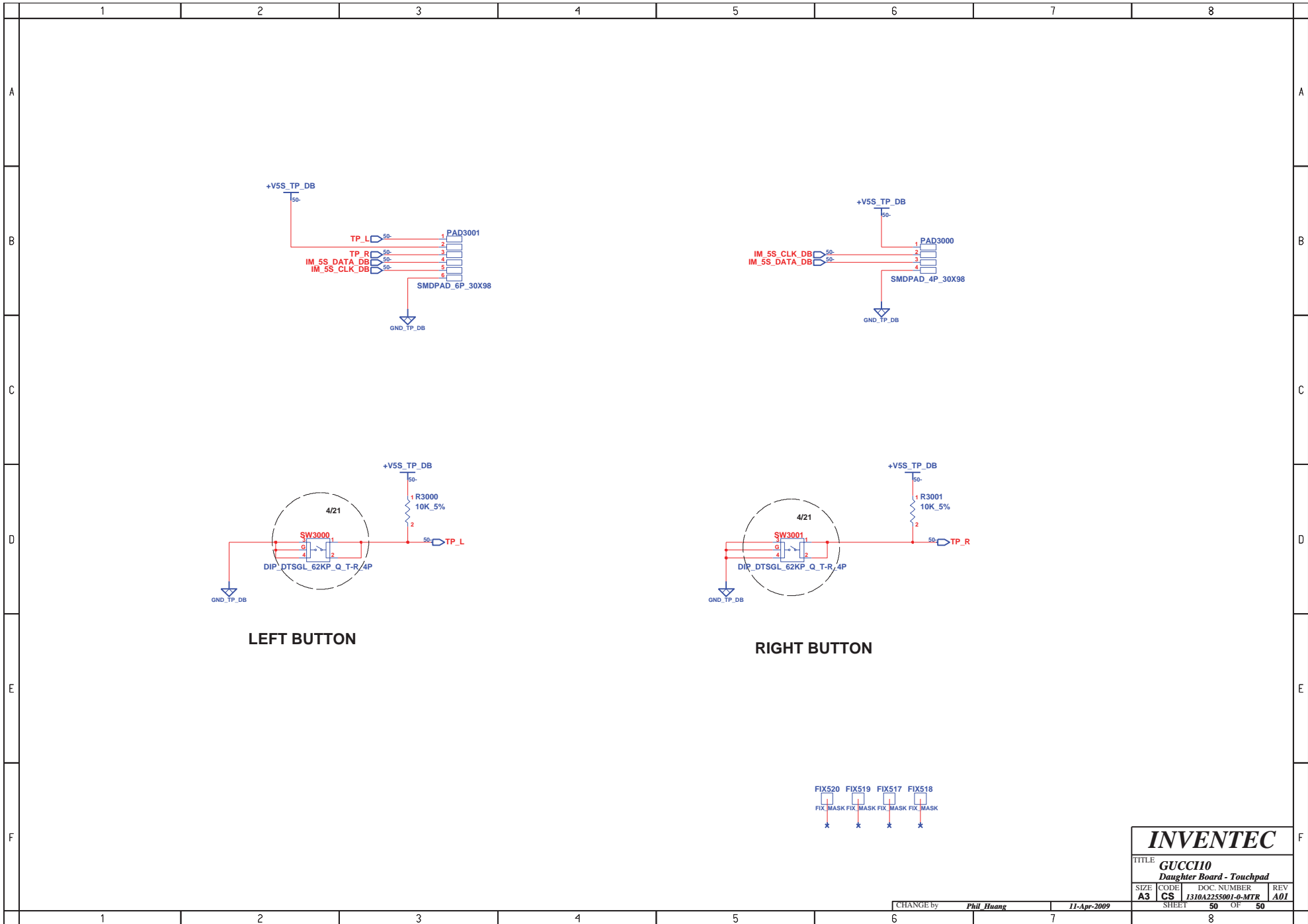

INVENTEC			
TITLE GUCCI10			
Daughter Board - Touchpad			
SIZE A3	CODE CS	DOC. NUMBER 1310A2255001-0-MTR	REV A01
CHANGE by Phil Huang		11-Apr-2009	
SHEET 50		OF 50	